



FMB-G-25SS-2-GN

Buton de iesire tip "ciuperca"

Imagine



YLI ETERNIT ACCES srl
A.: HAIDUCULUI 3A, CLUJ-NAPOCA
T.: +40 264 484989
W.: www.yli.ro

FMB-G-25SS-2-gn
Buton de iesire tip "ciuperca"
FISA TEHNICIA

Descriere

FMB-G-25SS-2-gn este un buton in forma de ciuperca, cu montare aplicata, confectionat din aliaj de zinc si cu un micro-switch cu contacte NO/NC. Butonul este usor de observat si de apasat. Designul rezistent la zgarieturi si constructia robusta antivandal permit instalarea acestuia in diverse locatii.

Caracteristici

• Montare	Aplicat
• Actionare	Prin apasare
• Iesire contact	NO/NC
• Tensiune/ curent maxim	36Vca/3A
• Alimentare	-
• Culoare buton	Verde
• Material	Aliaj de zinc
• Dimensiuni	53(H) x 53(l) x 26(A)mm
• Masa bruta	0.15kg
• Temperatura	-10°C~+55°C
• Umiditate	0-95%
• Aplicabilitate	Interior

Dimensiuni

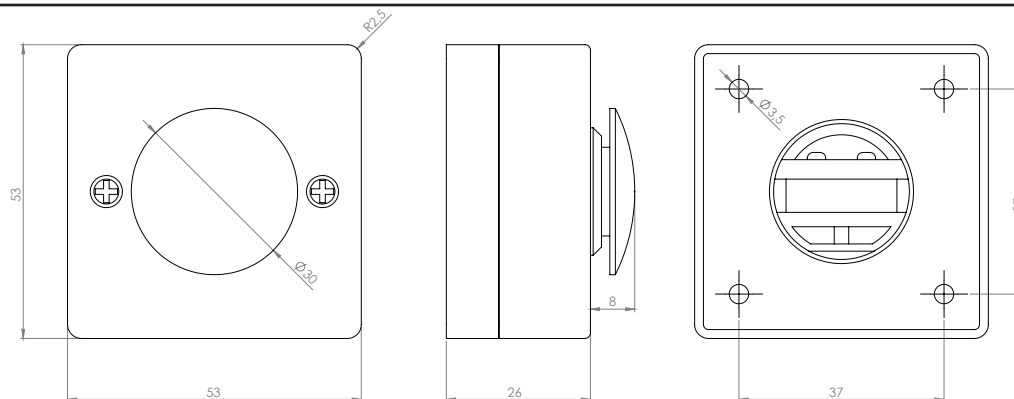

Conexiuni electrice

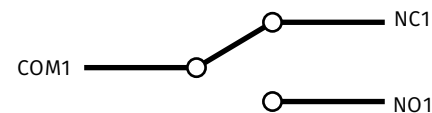
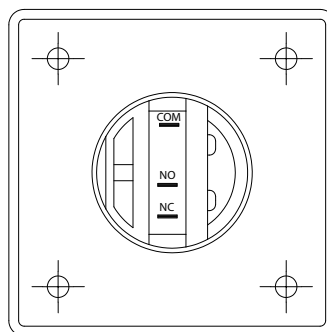

Montare

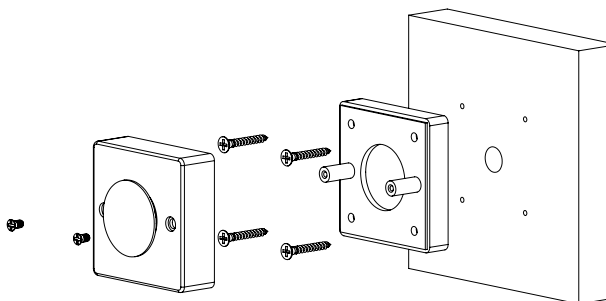

Observatii



EEE FAC OBIECTUL UNEI
COLECTARI SEPARATE

