

User manual

Install, setup and using of NumberOk SMB
license plate recognition software.

User manual v. 1.5

Matches to software build №3.2

TABLE OF CONTENTS

1	Description and key specifications	3
2	Applications fields	4
2.1	Traffic control systems	4
2.2	Checkpoints, parking areas.....	5
3	System installation.....	6
3.1	Recommendations for video sources selection and connecting.....	6
3.1.1	Video sources	6
3.1.2	Connection diagrams	7
3.1.3	Requirements for shooting quality for confident recognition of license plates ...	8
3.2	Recommendation for camera's specs and mounting.....	12
3.2.1	Camera mounting angles and distances.....	12
3.2.2	Recommendations for camera's specifications	13
3.2.3	Cameras mounting examples	14
3.3	Recommendations for executive units connection.....	15
3.3.1	Control modules	15
3.3.2	Barrier control in automatic mode (basic)	18
3.3.3	Barrier control in discrete mode.....	19
3.4	Requirements to computer's hardware.....	20
4	NumberOk SMB software.....	21
4.1	NumberOk SMB software editions	21
4.2	NumberOk SMB software operation modes.....	21
4.3	NumberOk SMB software installation and registration	24
4.3.1	NumberOk SMB software activation/deactivation.....	25
4.3.2	Selecting of NumberOk SMB installation configuration	26
4.3.3	NumberOk SMB installation - the final	28
4.4	NumberOk SMB launch as Operating System service.....	28
4.5	«View» tab.....	32
4.6	«Results» tab	33
4.6.1	Sub-tab «Recognition results».....	33
4.6.2	Sub-tab «Grouped by number»	34
4.6.3	Sub-tab «Parkings».....	35
4.7	«Reports» tab	37
4.7.1	Sub-tab «Recognition results».....	37
4.7.2	Sub-tab «Grouped by event»	38
4.8	«Car database» tab.....	39
4.8.1	Sub-tab «Vehicles».....	39

4.8.2 Sub-tab «Groups and ACS»	40
4.8.3 Sub-tab «Reactions»	42
4.9 «Settings» tab	47
4.9.1 Sub-tab «General»	47
4.9.2 Sub-tab «Connection»	49
4.9.3 Sub-tab «Checkpoint»	53
4.9.4 Sub-tab «Integration»	59
4.9.5 Sub-tab «Users»	61
5 Legend, terms and algorithms	62
5.1 Checkpoints types	62
5.1.1 One-directional checkpoints without entry confirmation	62
5.1.2 Two of one-directional checkpoints with entry confirmation	64
5.1.3 Bi-directional checkpoints with entry confirmation.....	67
5.2 Algorithms	70
5.2.1 License plate number recognition algorithm.....	70
5.2.2 Algorithm for plate movement direction identification	71
5.2.3 Algorithm for entry detection	72
5.2.4 Algorithm for calculation of vehicle stay at the territory duration.....	74
5.3 Legend.....	74
6 Troubleshooting	76
7 Appendix	77
7.1 Typical RTSP strings for some manufacturers equipment.....	77
7.2 Example of vehicles database export to *.xls format	78
7.3 The license plates patterns	79

1 DESCRIPTION AND KEY SPECIFICATIONS

NumberOk software-hardware complex designed for vehicles license plate recognition and control of access system executive units.

Table 1: NumberOk SMB key specifications

Name	Value
Operation system	Windows 7/8/10 family, Windows Server 2000 and higher, Windows virtual machines
Security system	Electronic keys
Number of connected video streams, pcs	1, 2, 4, 6, 9
Number of recognition zones in single video stream, pcs	up to 4
Single video stream rate, Mbit/s	up to 8
Single video stream resolution, MP	up to 3
Recognition rate (1920x1080), ms	10-100
Type of recognized license plate numbers	EU countries, CIS countries, Israel, Turkey
Recognition accuracy, %	>95
Vehicle speed, km/h	up to 240
Number of managed executive units (gates, barriers), pcs	up to 4
Number of monitored alarm sensors (photocells, induction loops), pcs	up to 8

2 APPLICATIONS FIELDS

2.1 TRAFFIC CONTROL SYSTEMS

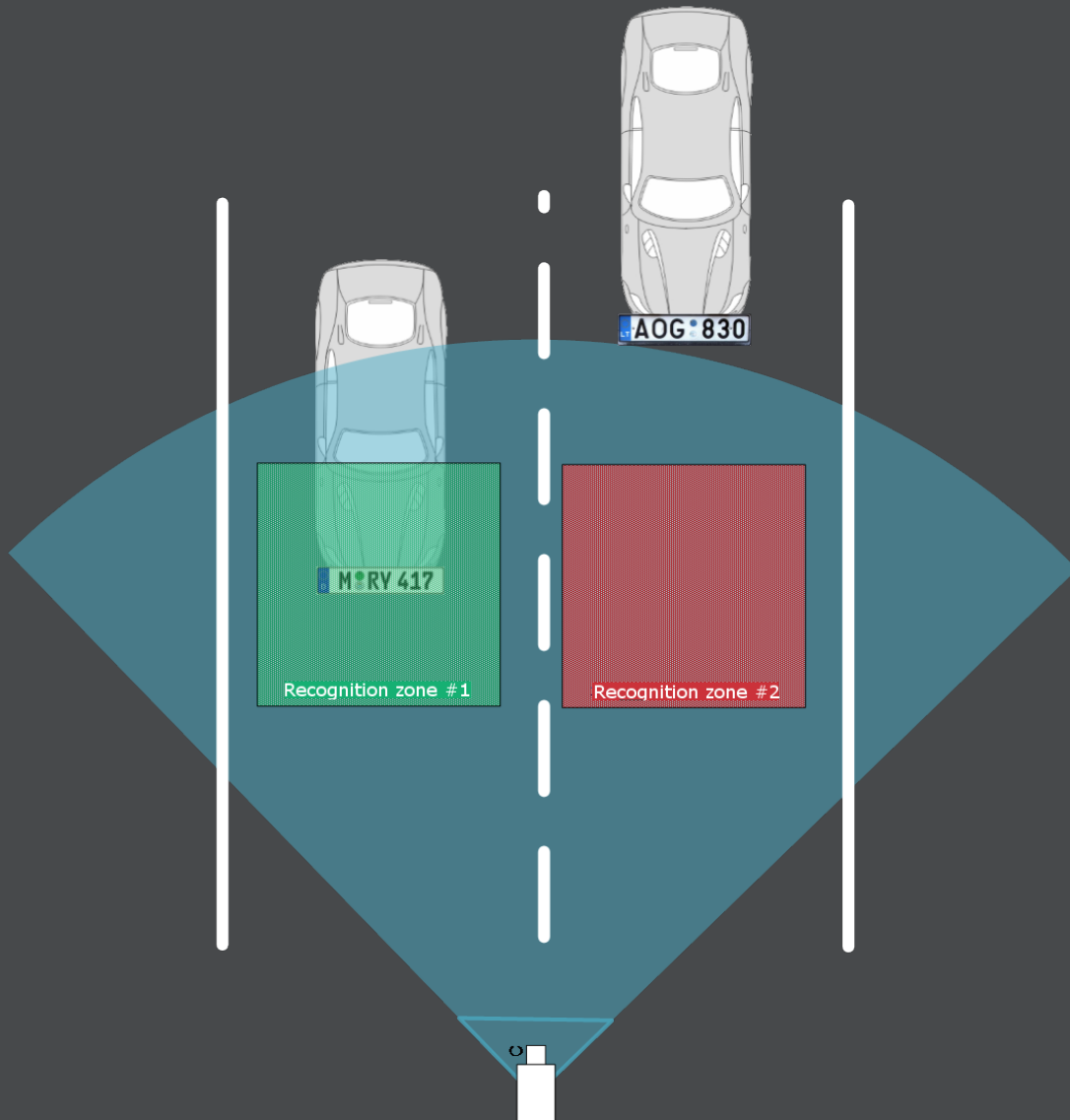

PICTURE 1: TRAFFIC CONTROL

Main objectives:

- Recognize license plate numbers and store it in the database;
- Determine the vehicles passage direction;
- Search database for certain vehicle (hijacked, debtors);
- Supply received data to an external systems;
- Generate reports for selected time period.

2.2 CHECKPOINTS, PARKING AREAS

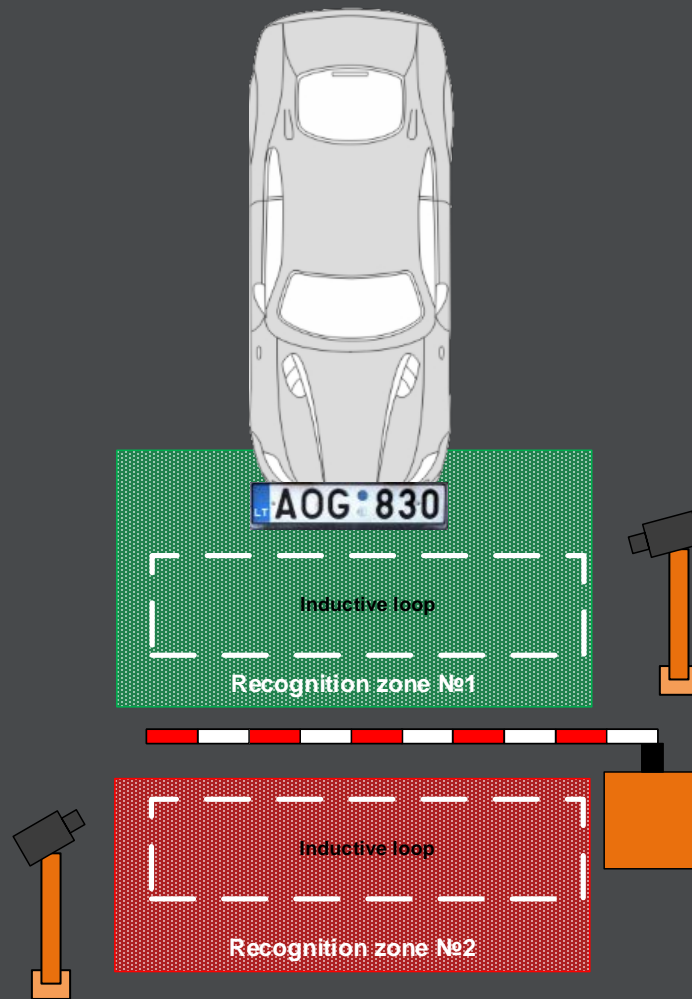

PICTURE 2: CHECKPOINT

Main objectives:

- Control vehicle access to the area;
- Detect vehicles entry and passage direction;
- Control barriers (gates) and obtain data from photo sensors (inductive loops);
- Calculate vehicle duration of stay at the area;
- Generate reports for define period.

3 SYSTEM INSTALLATION

3.1 RECOMMENDATIONS FOR VIDEO SOURCES SELECTION AND CONNECTING

3.1.1 VIDEO SOURCES

NumberOk SMB receives and decodes video streams in the next formats:

1. Live 555 library:
 - RTSP stream;
2. FFMPEG library:
 - AV_CODEC_ID_H264;
 - AV_CODEC_ID_MPEG4;
 - AV_CODEC_ID_HEVC.

Video stream sources:

1. IP cameras, supporting RTSP stream;
2. Analog cameras connected via DVR:
 - DVR Hikvision;
 - DVR Dahua;
 - DVR TVT;
 - DVR NOVUS;
 - DVR NUUO;
 - СВН Линия;
 - Any DVR supporting RTSP stream.
3. Any video sources supporting RTSP stream.
4. Local video files:
 - Codec: H264;
 - Container: AVI, MP4, TS.

For detailed information of video sources connecting to NumberOk SMB, refer to the [p.4.9.2.1](#).

3.1.2 CONNECTION DIAGRAMS

3.1.2.1 DIAGRAM FOR ANALOG CAMERAS CONNECTION THROUGH DVR

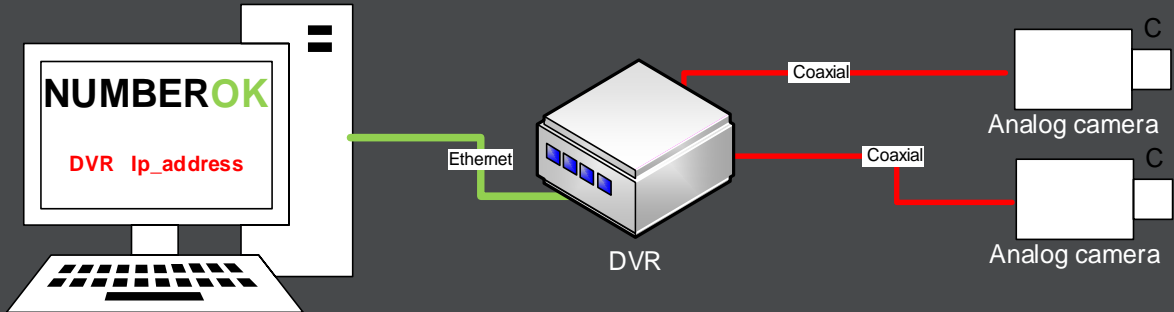

PICTURE 3: ANALOG CAMERAS CONNECTION DIAGRAM

3.1.2.2 DIAGRAM FOR IP CAMERAS CONNECTION

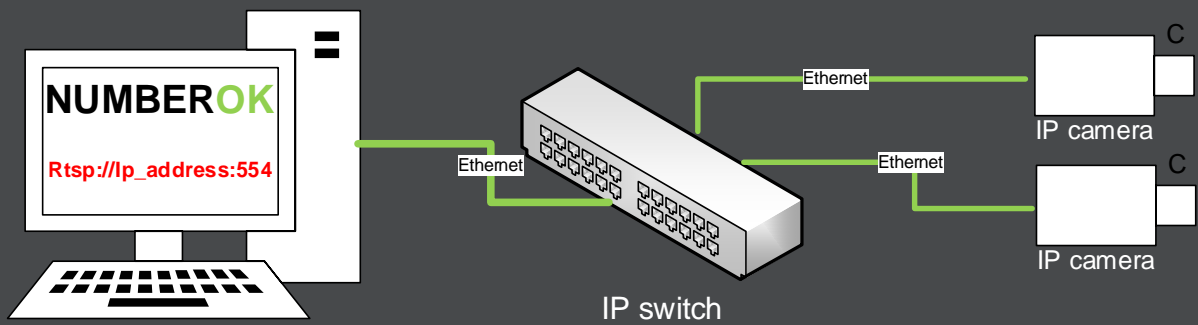

PICTURE 4: IP CAMERAS CONNECTION DIAGRAM

3.1.3 REQUIREMENTS FOR SHOOTING QUALITY FOR CONFIDENT RECOGNITION OF LICENSE PLATES

3.1.3.1 LICENSE PLATE NUMBER SIZE



PICTURE 5: RECOGNITION REQUIREMENTS - LICENSE PLATE SIZE

- **Minimum** size of number plate in the frame - **130 pixels**;
- Maximum size of number plate in the frame - 500 pixels;
- Recommended size of number plate in the frame - 150-200 pixels.

3.1.3.2 IMAGE QUALITY

The image of license plate number should be clear, contrast and easy-to-read.

Table 2: Assessment of image quality for license plate recognition

GREAT

License plate number is clear and easy-to-read



BAD

The license plate number of rear car is partly hidden by front car, the last symbol recognition error is possible. Nonetheless, the image is clear.

The front license plate number is not readable. Camera lens has insufficient depth of focus and cannot provide the clear image.



BAD

The image is not clear due to the low frame rate or wrong shutter speed set. The faster travelling speed of the vehicle is, the smaller this parameter should be. Camera settings adjusting required.

Available values: 1/250, 1/500, 1/1000



BAD

The license plate overexposed by the vehicle headlights.

Recommendation: use cameras with BLC and HBLC functions, True WDR technology and use manual shutter speed settings. Adjust HBLC response zones on frame areas with headlights.



BAD

The license plate image has geometric distortion due to short focus of camera lens.

Recommendation: install the camera at a longer distance from the subject; choose a optics with longer focal length.

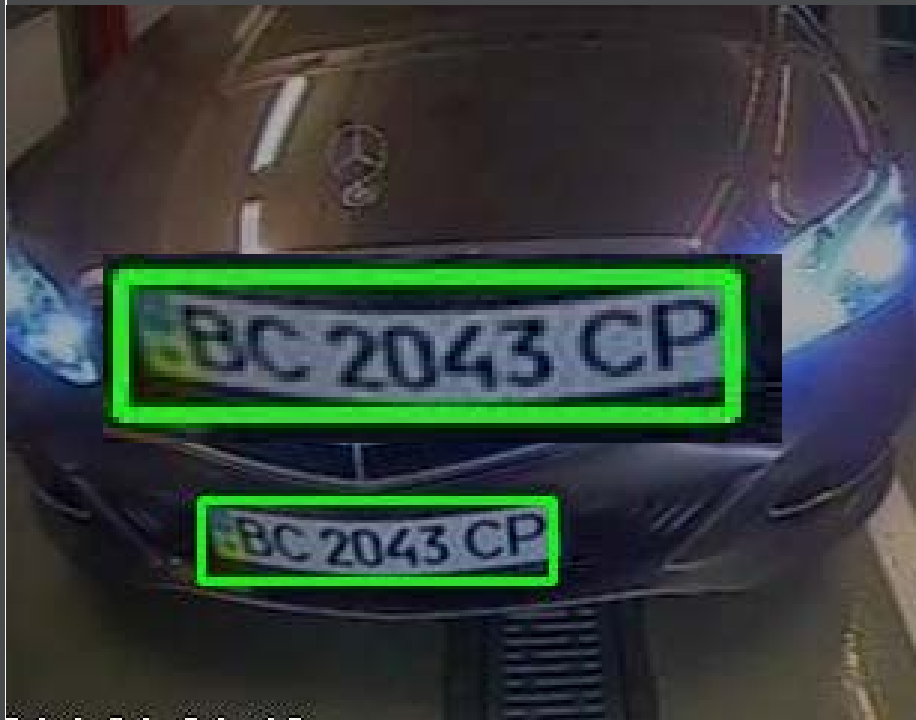

BAD

The license plate image has geometric distortion due to the big vertical view angle of the camera.

Recommendations:
mount the camera lower, in accordance with [p.3.2.1](#) recommendations.



3.2 RECOMMENDATION FOR CAMERA'S SPECS AND MOUNTING

3.2.1 CAMERA MOUNTING ANGLES AND DISTANCES

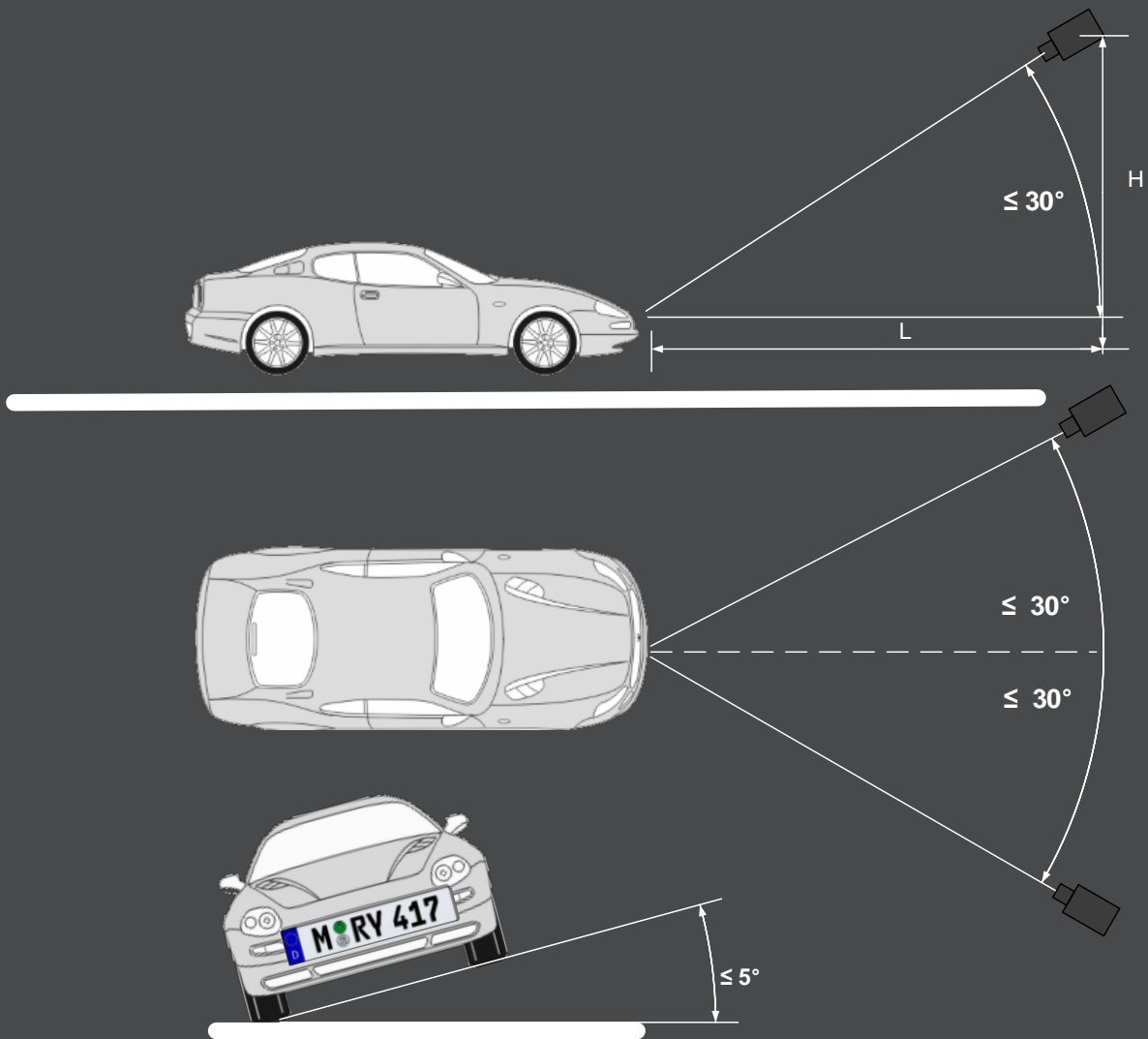

PICTURE 6: RECOGNITION REQUIREMENTS - CAMERA VIEW ANGLES

- Installation angle for **vertical mounting (tilt)** - up to 30 degrees;
- Installation angle for **horizontal mounting (yaw)** - up to 30 degrees;
- Bank angle **should not exceed ± 5 degrees**;
- Distance "L" to the vehicle can vary with all the requirements are met: installation angles, lack of geometric distortion and sufficient license plate size at the achieved images;
- Camera mounting height "H" can vary, providing installation angle in vertical plane less than 30 degrees.

3.2.2 RECOMMENDATIONS FOR CAMERA'S SPECIFICATIONS

The picture below illustrates the installation example for NumberOK system.

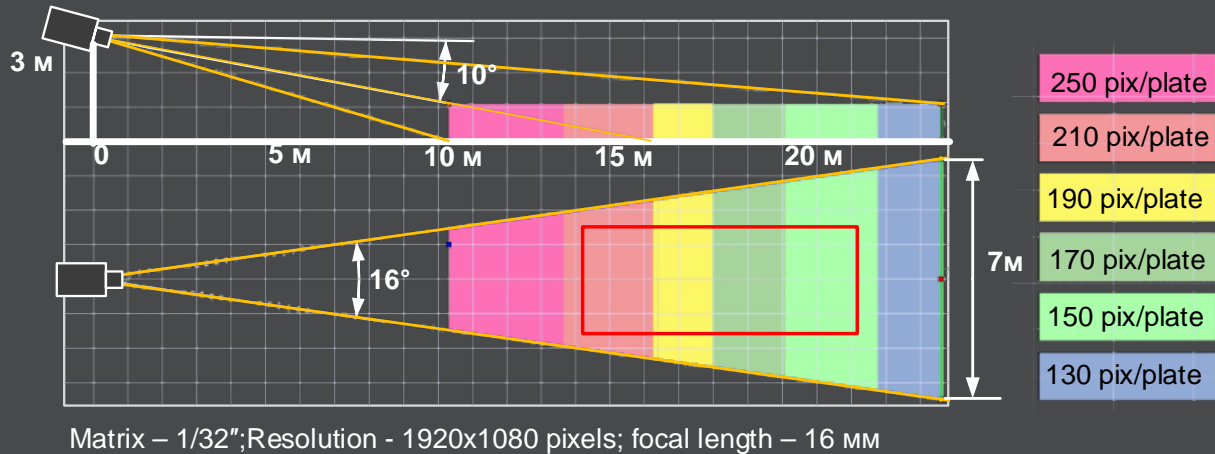

PICTURE 7: CAMERA INSTALLATION EXAMPLE

Requirements: detect license plate numbers within the 10-m long and 3-m wide area.
(See **PICTURE 7** - the area is surround with red rectangle)

Solution:

1. Select camera installation point given the technical conditions at the mounting site. In the example, the installation camera height is 3 m and the distance to recognition zone is 14 m, with camera focused at the center of the zone. Therefore we obtain tilt angle of 10° (with accordance to the recognition requirements ([p.3.2.1](#)));
2. Select lens. Focal length should be adjust in a way to provide maximum frame depth of field. In the example, the focal length of the lens we use is 16 mm.
3. Select camera resolution: Refer to the requirements of [p.3.1.3.1](#). The horizontal size of the license plate would have at least 130 pixels. In this case, the minimum possible resolution is FULL HD (1920x1080).

Conclusion: According to the results obtained, we can choose IP camera with 1920x1080 resolution or analogue HD CVI camera with the same resolution.

We have determined one possible installation point of the camera. The similar calculation can be perform for all available mounting points in order to choose the most suitable.

The table below illustrates two examples of camera installation:

3.2.3 CAMERAS MOUNTING EXAMPLES

Table 3: Typical camera mounting examples

	Example №1	Example №2
Camera type	IP 	Analogue 
Resolution, pixels	1920x1080	704x576
Lens	Fixed focal length 6 mm	Varifocal lens 6-12 mm
Mounting features		
Mounting height, meters	3	1
Field of view		
Recognition zone width, meters	12	4

3.3 RECOMMENDATIONS FOR EXECUTIVE UNITS CONNECTION

3.3.1 CONTROL MODULES

NumberOk support next control modules types:

- «BARBOS» control module;
- ICP CON PET-7060 control module, connected by ModBUS;
- Other devices with ModBUS connection.

Two BARBOS units and three ICP CON devices can be connect to NumberOK simultaneously.

Control modules allows connecting up to **four barriers** and receiving data from **four alarm sensors** (inductive loops or photo sensors).

3.3.1.1 «BARBOS» CONTROL MODULE



PICTURE 8: «BARBOS» CONTROL MODULE

BARBOS designed to control executive units via four relay output channels, as well as to receive information about the device states via four channels of alarm outputs.

BARBOS controlled by NumberOK via *USB* interface. The device is easy to install, operate and maintain. It is available in durable plastic case and could be mount without external box. All connectors are removable and equipped with explanatory pictograms to simplify connection process.

Table 4: «BARBOS» specifications

Alarm inputs	
Number of channels, pcs.	4
Alarm outputs actuation time, ms	100
Galvanic isolation	yes
Isolation voltage rating, kV	1
Relay outputs	
Number of channels, pcs.	4
Isolation voltage rating, kV	1

General	
Power supply, V	5 DC (via USB)
Power consumption, mA	not more 500
Overall dimensions (Wx D x H), mm	134 x 89 x 34
Operating temperature range, °C	-20 - +50
Operating humidity, %	Up to 90

3.3.1.2 ICP DAS PET-7060 CONTROL MODULE



PICTURE 9: ICP CON PET-7060 CONTROL MODULE

ET-7060 is a 6-channel isolated discrete input module with 32-bit counter and 6-channel relay output with integrated web-server. The device serves as data storage and control module with ModBUS/TCP protocol connection. It allows the organizing of the remote input/output system via Ethernet network.

3.3.1.3 EXECUTIVE UNITS CONNECTION VIA MODBUS PROTOCOL

NumberOk support the connection of other devices with ModBUS protocol when it have the Inputs and Outputs counter registers.

The user should enter the numbers of the respective registers in the ModBUS connection configuration of NumberOk in accordance with the documentation of the device. For the debug simplifying use the utility, included in NumberOk pack. It obtaining a dump of the ModBUS registers not equal to zero.

The utility runs in the command line in the format: DumpModBus.exe IP NetID, where:

IP - IP address of the ModBUS device;

NetID - the device ID in the ModBUS.

Table 5: ICP CON PET 7060 specifications

Network interfaces	
Number of ports, connector type	1x10/100 Mbit/s, RJ-45
Industrial interfaces/Protocols	
ModBUS TCP/ModBUS UDP support	Slave/Slave
Digital input	
Number of digital input channels, pcs.	6
Type:	Contact with external power supply
Sink/Source:	Sink, Source
Digital output	
Number of digital output channels, pcs.	6
Type	Power Relay, Form A (SPST NO)
General	
Powered from Terminal Block, V	10 - 30 DC
Consumption, W (max)	2,8; PoE support
Reverse Polarity Protection	Yes
Environmental	
Operating Temperature, °C	-25 - +75
Humidity, %	10 ~ 90 RH, Non-condensing

CAUTION! Vendor can modify product specification. You can get actual data at the vendor's site: www.icpdas.com

3.3.2 BARRIER CONTROL IN AUTOMATIC MODE (BASIC)

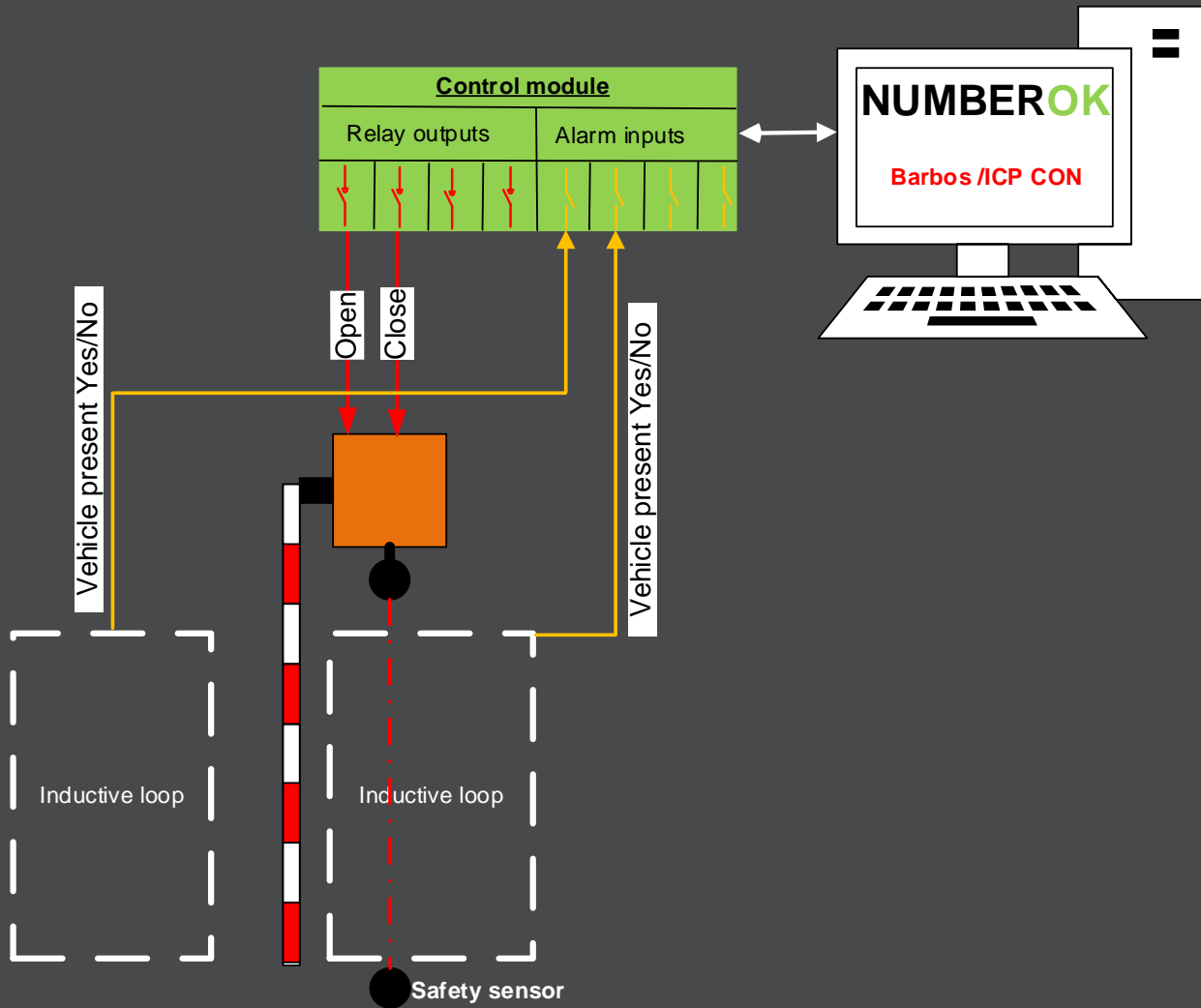

PICTURE 10: MULTI-USER BARRIER OPERATING MODE

Output relays of control module connected to barrier controller in this mode. **Two relays** used: the first one transmits the command «Open», and the second one - «Close». Control module relays can be connect in parallel with barrier operating buttons. The barrier control unit and NumberOk control module can work simultaneously without mutual interference. **This basic operating mode is preferred and most secured.** When user wants to detect vehicle entry by the alarm sensors, the control module can be connect to normally closed (NC) inductive loops or photocell sensors. Functionality algorithm describes in [p.5.2.3.1](#)

3.3.3 BARRIER CONTROL IN DISCRETE MODE

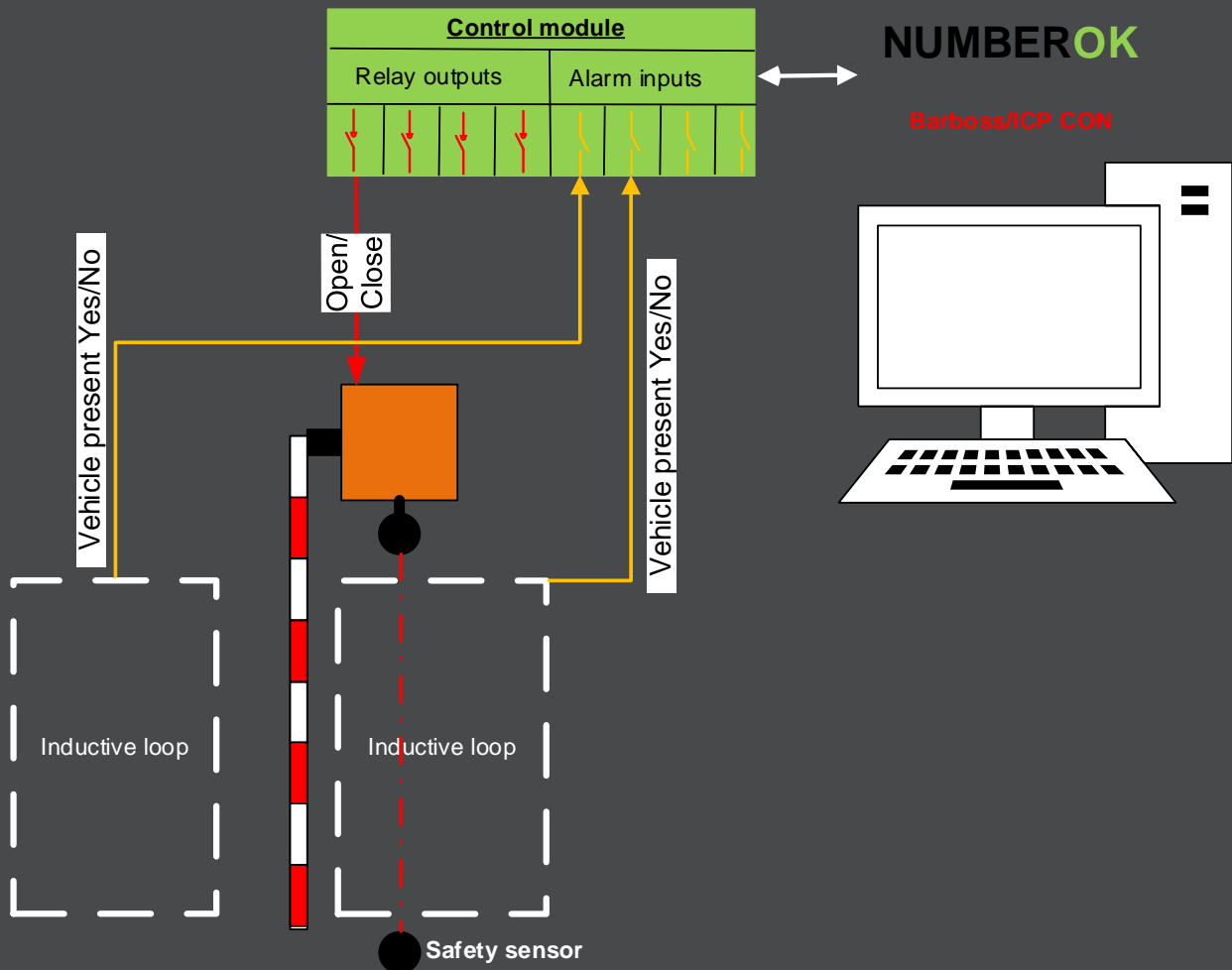

PICTURE 11: BARRIER CONTROL DISCRETE MODE

In this mode, output relays of control module connected to the barrier controller. **One relay** is involved in the process. When the relay closed for the first time, the "Open" signal sending to the control unit to open executive mechanism. When the relay closed for the second time, the control unit performs closing of the barrier. Control module relay can be connected in parallel with barrier operation button. Simultaneous operation of barrier control panel and control module is possible but unwelcome. NumberOK does not track the control unit commands and cannot determine executive mechanism state (opened or closed). **Discrete operating mode is not secure.** When user wants to detect vehicle entry by the alarm sensors, the control module can be connect to normally closed (NC) inductive loops or photocell sensors. Functionality algorithm describes in [p.5.2.3.1](#)

3.4 REQUIREMENTS TO COMPUTER'S HARDWARE

The hardware requirements to the computer will run NumberOk, depends on the connected video channels amount and it frame rates. The approximate parameters shown in the table:

Table 6: Required computer's hardware parameters

Channels number, pcs.	1	2	4	6	9
Resolution	D1 (704x576)- 4K (4096x3112)				
Frame rate, fps	12 - 25				
CPU *	Intel i3-4330	Intel i5-4440	Intel i7-4770K	Intel i7-5820K	Intel i7-5960X
RAM, GB	4	4	8	8	8
HDD **, GB	50	150	300	500	1000
Operating system	Windows XP/vista/7/8/10 family, Windows Server 2000 and higher, Windows virtual machines				

* - The required processors computing power in systems with an equal amount of channels depends on it the resolutions, the vehicles speed and the recognition zones area.

** - The specified hard disk space required for software installation and cameras screenshots saving. The NumberOk software do not save video data, the extra storage volume for the video archive is not considered.

4 NUMBEROK SMB SOFTWARE

4.1 NUMBEROK SMB SOFTWARE EDITIONS

NumberOk SMB software editions may vary by next parameters:

- By channels amount:
 - One channel;
 - Two channels;
 - Four channels;
 - Six channels;
 - Nine channels;
- By regions:
 - CIS region;
 - EU region + Israel;
- By duration:
 - Full version- unlimited time;
 - Demo version - 15 days (requires permanent Internet connection).

4.2 NUMBEROK SMB SOFTWARE OPERATION MODES

NumberOk SMB system provides next operation modes:

I. Recognition (basic mode)

Basic functions:

- License plate recognition;
- Recognition of the vehicle's travel direction;
- Analyzing of vehicle groups movement;
- Reports generation;
- Transfer of recognized number plates to external applications;

Basic data parameters transferred to external applications:

- License plate number;
- License plate description - the field is blank, when license plate number not available in database;
- Group - the field is blank, when license plate number not available in database;
- Vehicle passage direction:
 - Entry;
 - Exit;
 - Undetermined;
- Technical information:
 - License plate number horizontal size in pixels;
 - Recognition time;
 - License plate number recognition accuracy;
 - Amount of recognitions;
 - Country indicator;
- The country where license plate number is registered.

II. Checkpoint (access control)

Basic functions:

- License plate recognition;
- Access to the territory management;
- Recognition of checkpoint passage direction;
- Analyzing of vehicle groups movement;
- Calculating of the “stay at the territory” duration for individual vehicles and groups;
- Limiting of the “stay at the territory duration” for individual vehicles and groups;
- Setting up the visual and sound reactions for checkpoint events;
- Control of the checkpoint executive units;
- Reports generation;
- Transfer of recognized number plates data to external applications;

Basic data parameters transferred to external applications:

- License plate number;
- License plate description - the field is blank when license plate number not available in database;
- Group - the field is blank when license plate number not available in database;
- Vehicle passage direction:
 - In one stage:
 - Entry;
 - Exit;
 - In two stages (with entry/exit confirmation):
 - Entry attempt;
 - Entry;
 - Exit attempt;
 - Exit;
- Technical information
 - License plate number horizontal size in pixels;
 - Recognition time;
 - License plate number recognition accuracy;
 - Amount of recognitions;
 - Country indicator;
- The country where license plate number is registered;
- Access permit:
 - Allowed;
 - Allowed by date;
 - Allowed by “stay at the area” duration;
 - Allowed by entry numbers.

Refer to [p.4.9.3](#) for more detailed checkpoint settings.

III. Parking (parking areas management and access control)

Basic functions:

- License plate recognition;
- Recognition of checkpoint passage direction;
- Analyzing of vehicle groups movement;
- Managing of several parking areas:
 - Managing of empty slots at the parking areas;
 - Access to the parking areas by extended parameters set for registered and unregistered vehicles;
 - Calculating the "stay at the territory" duration for individual vehicles and groups;
 - Monitoring and limiting the "stay at the territory" duration for individual vehicles and groups;
 - Setting up the visual and sound reactions for parking events;
- Executive units control;
- Reports generation;
- Transfer of recognized number plates data to external applications;

Basic parameters of data, transferring to external applications:

- License plate number;
- License plate description - the field is blank when the license plate number not available in database;
- Group - the field is blank when the license plate number not available in database;
- Vehicle passage direction:
 - In one stage:
 - Entry;
 - Exit;
 - In two stages (with entry/exit confirmation):
 - Entry attempt;
 - Entry;
 - Exit attempt;
 - Exit;
- Technical information
 - License plate number horizontal size in pixels;
 - Recognition time;
 - License plate number recognition accuracy;
 - Amount of recognitions;
 - Country indicator;
- The country where license plate number is registered;
- Access permit:
 - Allowed;
 - Allowed by date;
 - Allowed by "stay at the area" duration;
 - Allowed by entry numbers.

4.3 NUMBEROK SMB SOFTWARE INSTALLATION AND REGISTRATION

For installation start, you have to run installer file *anpr_setup.exe* as administrator. It can be found at installation disk or download from site Number-Ok.com.

CAUTION! Running the NumberOk SMB installer as administrator - is a necessary requirement for correct installation.

Select one of the interface languages of the installer. You can change it after installation.

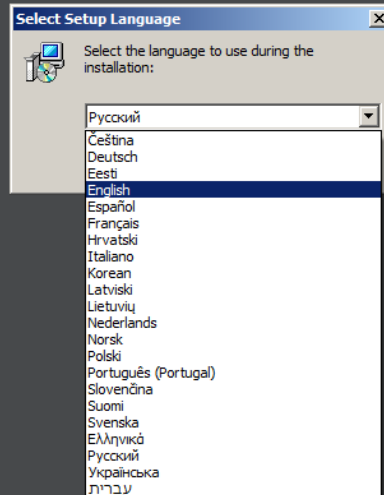

PICTURE 12: NUMBEROK SMB INSTALLATION - LANGUAGE SELECTION

Next step - enter the license key in special window:

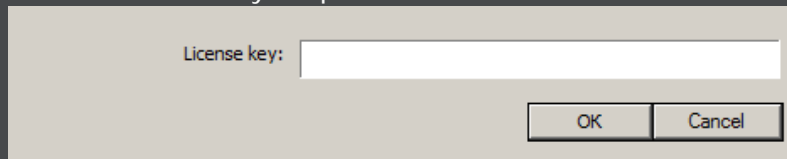

PICTURE 13: NUMBEROK SMB INSTALLATION - LICENSE KEY ENTERING

License key situated in purchased software pack, sent by e-mail when you purchase online license or use the NumberOk demo version. Enter the key sequence precisely, complying with the dividers and characters register. Do not enter extra spaces or extra punctuation.

4.3.1 NUMBEROK SMB SOFTWARE ACTIVATION/DEACTIVATION

After entering a valid license key, the setup wizard starts NumberOk SMB installation. There are two types of activation: **online activation** ([p.4.3.1.1](#)) - when Internet connection is available, **offline activation** ([p.4.3.1.2](#)) - without Internet connection.

4.3.1.1 ONLINE ACTIVATION OF NUMBEROK SMB SOFTWARE LICENSE

CAUTION! Internet connection required for online activation during license key entering.

For further **work with the demo version**, the Internet connection should be permanent.

After entering a valid license key clicking "Next" button will open a new window with a warning to disable the anti-virus package during installation of a software and FTDI controller drivers.

The next NumberOk SMB installation process described in [p.4.3.2](#).

4.3.1.2 OFFLINE ACTIVATION OF NUMBEROK SMB SOFTWARE LICENSE

After entering a valid license key without Internet connection, clicking "Next" button will open a software offline activation form:

Enter license key

Send generated data to support@number-ok.com

Key: NUMBER-20200-HEART-LINKS
Request: 88A27 817 2048F0A17A 344A 2020A: 4F708 4811A 0A 8BFC7F 12754462D 82

Paste received answer here:

PICTURE 14: OFFLINE ACTIVATION FORM

You have to copy and send generated activation request data from the middle window of the request form to NumberOk SMB support service to the e-mail address: support@number-ok.com. The necessary information is contained in the **Request:** string. But you can just select all the data from the window. If you copy and send them all - it will not be an obstacle for the generation of the correct activation answer. You have to pay attention that the **Request:** data string is much longer than the width of the form window. It has to be copied completely, not just the visible area.

Received from NumberOk SMB support service the activation answer string have to be completely copied to the lower window of activation form **Paste received answer here:**. Clicking "Ok" button will open a new window with a warning to disable the anti-virus package during installation of a software and FTDI controller drivers.

The next NumberOk SMB installation process described in [p.4.3.2](#).

4.3.1.3 DEACTIVATION OF NUMBEROK SMB SOFTWARE

CAUTION! When you need to transfer NumberOk SMB software to another computer, or upgrade the hardware of the computer where NumberOk SMB installed and activated, **it is necessary to deactivate** the current NumberOk SMB license **before** the another copy of the software would be uninstalled. The NumberOk SMB license key links exactly to computer's hardware. For NumberOk SMB transfer to another hardware you have to:

- deactivate license key at the old hardware ([p.4.9.1](#));
- install and reactivate it at the new hardware ([p.4.3](#)).

4.3.2 SELECTING OF NUMBEROK SMB INSTALLATION CONFIGURATION

Installer wizard of the NumberOk SMB software allows two configurations: local and client-server. Both options allow you to integrate them with the 1C 8.x version software. For this purpose, you need to implement 1C extension component in the NumberOk SMB system. It can be download from the website www.number-ok.com.

4.3.2.1 LOCAL CONFIGURATION

To operate NumberOk SMB for single checkpoint or observation post, the best would be to install a local database **Sqlite**. It is creates and resides on the same computer where you install the NumberOk SMB software and has the next limitations:

- Maximum number of events entries: 200 000;
- Maximum number of vehicle database records: 20 000.

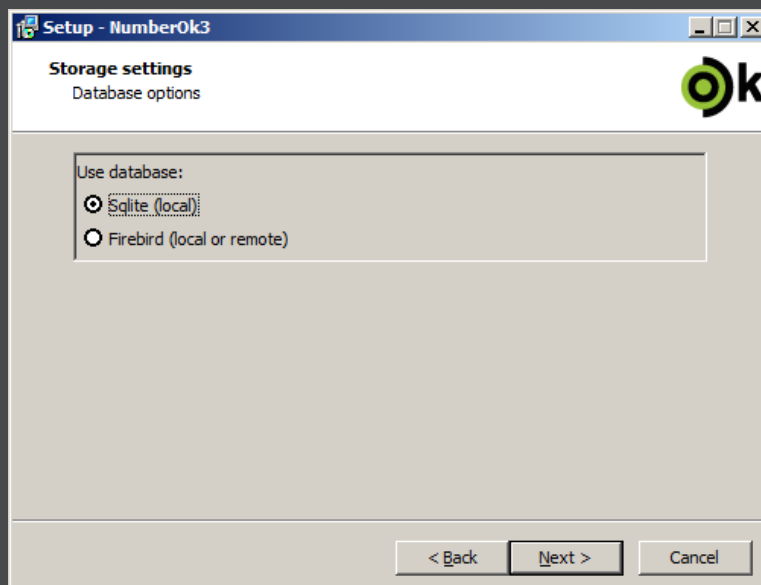

PICTURE 15: NUMBEROK SMB INSTALLATION - LOCAL DATABASE SELECTION

Press the "Next" button and proceed to the final stage of installation process in [p.4.3.3](#)

4.3.2.2 CLIENT-SERVER CONFIGURATION

To setup the access control system to the territory with multiple checkpoints and united database it would be optimal to create Firebird DB server at a dedicated computer. NumberOk client copies at each checkpoint will communicate with server via data networks. Limitations of client-server variant are significantly softer:

- o Maximum number of events entries: 1 000 000;
- o Maximum number of vehicle database records: 100 000.

The advantages are obvious: all NumberOk SMB copies at all checkpoints of the object use a single database. Updating and synchronization of any changes in this database happens at client checkpoints automatically. Analysis of the all gathered information can be provide in a remote data center without visit to each checkpoint. External applications also have access to copying and changing the data (e.g., a database of permitted vehicles).

4.3.2.2.1 SERVER SOFTWARE INSTALLATION

For a creation of NumberOk SMB network structure, you have to setup one copy of the program in the server configuration: specify "Firebird" at database select options, select the checkbox "Install Firebird server". **Leave all other window items without any changes!**

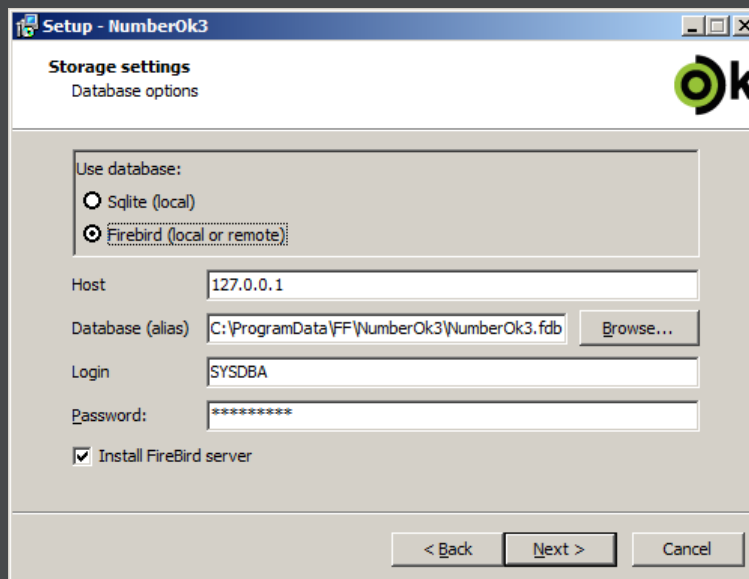

PICTURE 16: NUMBEROK SMB INSTALLATION - SERVER DATABASE SELECTION

Standard login for NumberOk SMB Firebird database: **SYSDBA**

Standard password for SYSDBA login: **masterkey**

Clicking the "Next" button will open the window of the Firebird server database deployment path selection (Recommendation: remember or write down it in another place.). Proceed to the final installation stage after it confirmation ([p.4.3.3](#)). NumberOk SMB installation in client configuration described below.

4.3.2.2.2 CLIENT SOFTWARE INSTALLATION CONFIGURATION

To install NumberOk SMB in client configuration you should choose the option with Firebird DB and **uncheck the "Install Firebird server"**. To configure a server connection you should set the next parameters:

- «Host» window: enter database server IP address;
- «Database (alias)» window: enter local path to database at the server or database alias;
- «Login» window: enter login for database access;
- «Password» window: enter password for selected login;
- **Check the "Install Firebird server" checkbox unchecking.**

Click the "Next" button after window parameters set.

4.3.3 NUMBEROK SMB INSTALLATION - THE FINAL

In the next screens, the installation wizard prompts you to select or enter the name of the folders where NumberOk SMB program itself and the screenshots from the cameras will be located. Then it will requests to create the Windows desktop icon, and will issue a warning about the work launch with specified parameters. Pressing the confirmation button will run the procedure of NumberOk SMB installation.

After NumberOk SMB installation complete, the setup wizard will offer you to add RS-232-USB FTDI converter drivers to the OS for communicate with "BARBOS" modules. Pressing «Extract» button will launch the self-extracting driver's installation wizard after windows with action confirmation and items to install selection.

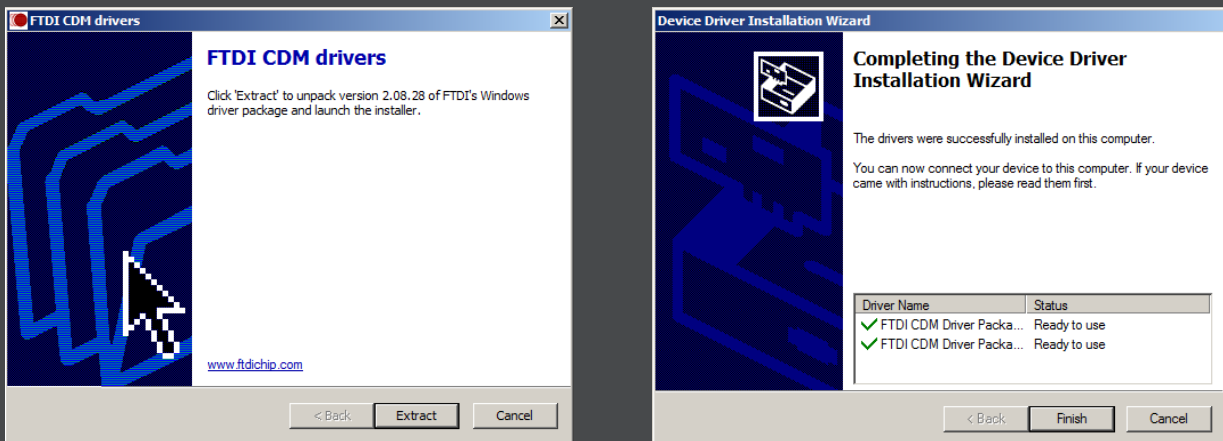

PICTURE 17: NUMBEROK SMB INSTALLATION - FINAL WINDOWS

Pressing «Cancel» button will complete the installation sequence without drives setting up. Performing all installation procedures allows you to run NumberOK SMB (p. 4.5).

4.4 NUMBEROK SMB LAUNCH AS OPERATING SYSTEM SERVICE

To operate the license plate recognition software in a distributed data processing systems on server platforms, NumberOk SMB can be launch as an operating system service, not as an application. In this form the program is better integrating into the multi-threaded environment, optimized to work with TCP/IP traffic and requires less computing power.

NumberOk software launch as a Windows service provides as follows:

- Install the NumberOk SMB software in required (local or client-server) configuration and enter the license key (p.4.3). It is necessary to customize the operation of NumberOk SMB as an applications thoroughly: connect all cameras and video sources, determine optimal areas and parameters for license plates recognition, configure the Firebird server (for server configuration) and enter correct data to communicate with the server software (for client configurations), set up the "Checkpoint" or "Parking" modes if necessary;
- Close NumberOk application;
- Launch Start LPR service utility from FF Group software folder as administrator. Launching as administrator - it is a critically important requirement for it correct installation;

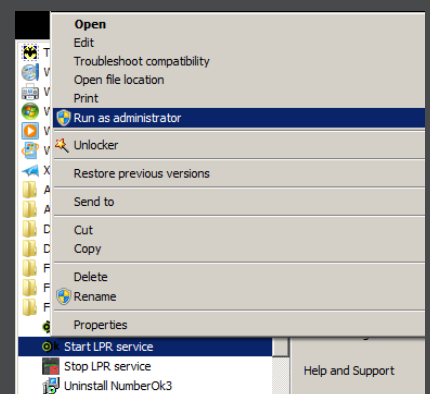

PICTURE 18: LAUNCH NUMBEROK SMB AS A SERVICE - SERVICE START

During the Service License plate recognition launch, the similar Command Prompt window have to appear, indicating the success of action:

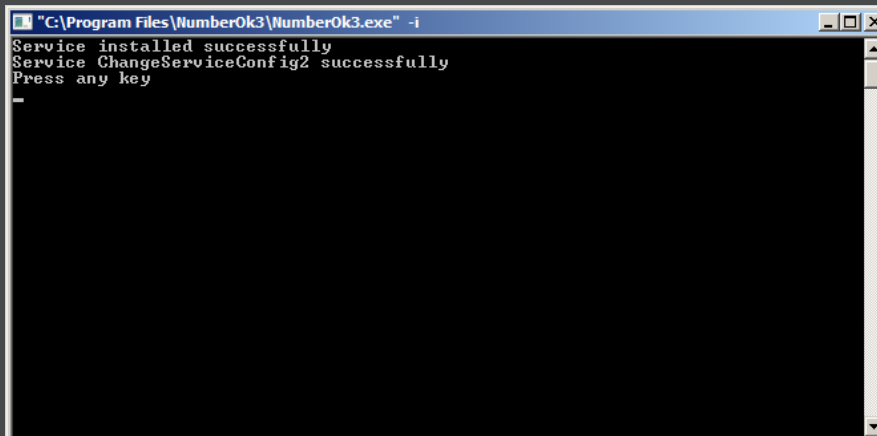

PICTURE 19: LAUNCH NUMBEROK SMB AS A SERVICE - SUCCESSFUL START WINDOW

If you try to run this program as a current user, you will see a Command Prompt window with an error:

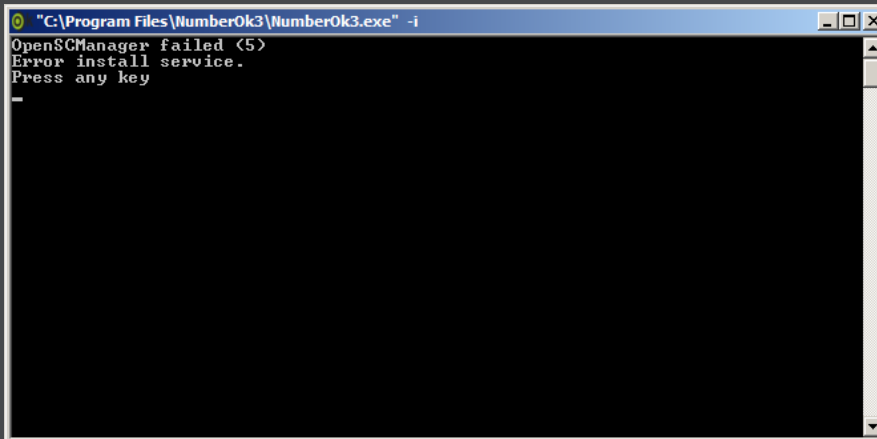

PICTURE 20: LAUNCH NUMBEROK SMB AS A SERVICE - ERROR START WINDOW

To improve the situation it is enough to make a new attempt to start the Start LPR service, [as an administrator!](#)

The operability of NumberOk SMB as an OS service can be checked in the window of running services list. You can access it by way: *Start-> Control Panel-> Administrative Tools> Services* or by pressing *Task Manager-> "Services" tab -> "Services" button*. There should be a line of Service License plate recognition service activity:

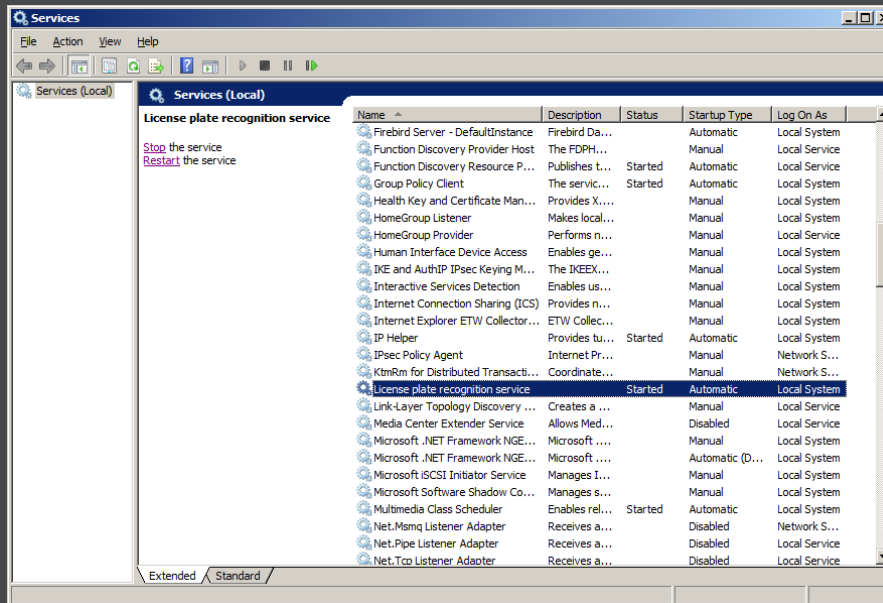

PICTURE 21: LAUNCH NUMBEROK SMB AS A SERVICE - WORKING AS A SERVICE

- Now NumberOk SMB will run as a Windows service. With the default settings (Startup type: Automatic), the program will automatically run each OS restart;
- You can stop, restart and start manually the License plate recognition service using the regular Windows tools. These actions are also available using utilities from the installed FF Group software folder: **Stop LPR service** and **Start LPR service**. But it is worth remembering that they have to be run only **as administrator**;

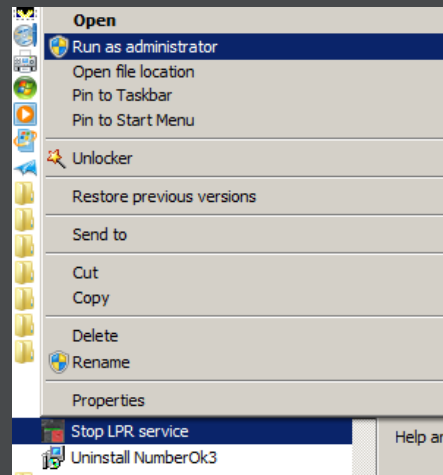

PICTURE 22: LAUNCH NUMBEROK SMB AS A SERVICE - SERVICE STOP

- For reliable uninterrupted long time operation of NumberOk SMB as a OS service it is necessary to customize it emergency restart:

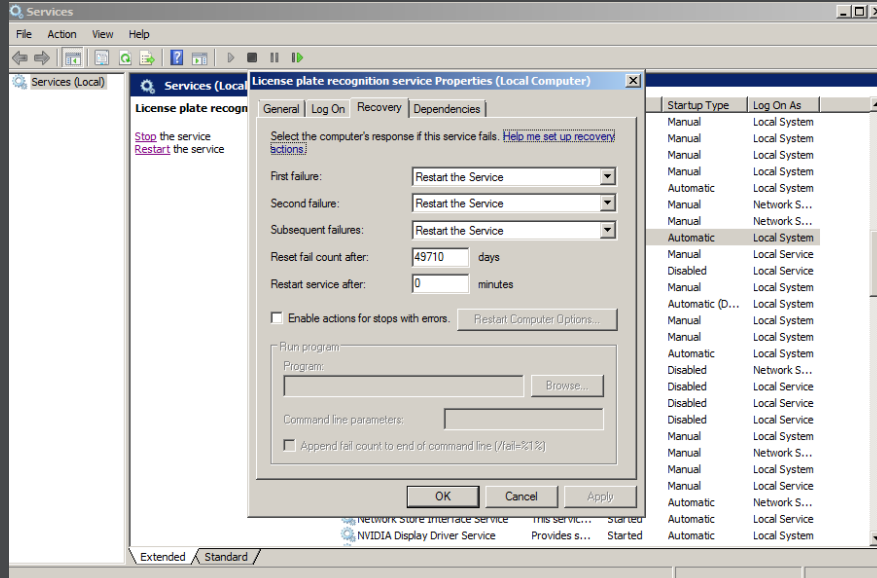

PICTURE 23: LAUNCH NUMBEROK SMB AS A SERVICE - SERVICE RESTART CUSTOMIZING

With these settings, the service does not require its periodical monitoring by the computer's administrator. It will automatically hidden restarted after the every failures and proceed to work.

4.5 «VIEW» TAB

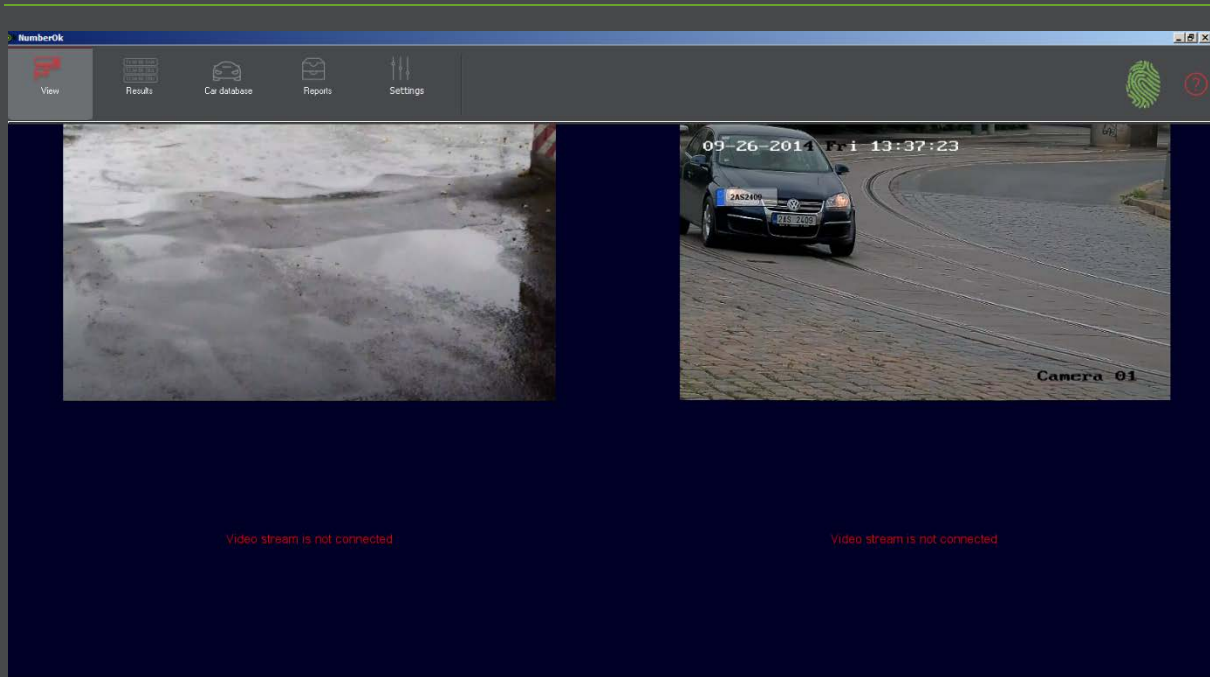

PICTURE 24: "VIEW" TAB

In this tab NumberOk demonstrate real-time video streams from connected sources. There are one, two, four, six or nine channels, depending on purchased license. Above them situated the tab bar of program's tools. Its appearance depends on the program functioning mode ([p.4.2](#))

On the video stream frame, NumberOk displays over the recognized vehicle license plate number (PICTURE 25):

- Recognized license plate number, if it is not present in the database. Or it description, if it is there. Double-clicking on this field will add the number to the database and switch to the tab "Car database" ([p.4.8](#)). Where the user can change the license plate groups affiliation;
- Information about denied or allowed access for this vehicle. **Available only in Checkpoint and Parking modes.**
- Vehicle group, if the license plate included in one of them. Double-clicking on described field adds the license plate number to the database and switch to the tab "Car database" ([p.4.8](#)). Where the user can change the number group affiliation;
- Duration of "stay at the area". **Available only in "Checkpoint" and "Parking" modes when vehicle direction detected as "Attempt to Exit" or "Exit".** Double-clicking on described field will take you to "Results" tab ([p.4.6](#)).



PICTURE 25: «VIEW» TAB - PARAMETERS OF RECOGNIZED LICENSE PLATE

4.6 «RESULTS» TAB

4.6.1 SUB-TAB «RECOGNITION RESULTS»

	Date	Owner	Group	Number plate	Photo	Direction	Channel	Zone	Technical data	Country	System ID
10	11.08.2015 15:12:09			05FLLN	05FLLN	↓	1	4	23ms/268px/0.79/10/247/NL		1
11	11.08.2015 15:12:06	34FHHV	New group "Denied"	34FHHV	34FHHV	↓	1	4	18ms/250px/0.89/20/247/NL		1
12	11.08.2015 15:12:01			4BJSRT	4BJSRT	↓	1	4	27ms/323px/0.78/21/243/NL		1
13	11.08.2015 15:11:55			62LXSK	62LXSK	↓	1	1	21ms/260px/0.78/19/243/NL		1
14	11.08.2015 15:11:52	27JHNR	New group "Denied"	27JHNR	27JHNR	↓	1	4	21ms/232px/0.77/6/NL		1
15	11.08.2015 15:11:49	XN FH 63	New group "Denied"	XN FH 63	XN FH 63	↓	1	1	23ms/251px/0.84/15/248/NL		1
16	11.08.2015 15:11:46	24DBNT	New group "Denied"	24DBNT	24DBNT	↓	1	1	24ms/243px/0.81/15/242/NL		1
17	11.08.2015 15:11:43	18KBR3	New group "Denied"	18KBR3	18KBR3	↓	1	1	23ms/256px/0.77/241/NL		1

PICTURE 26: «RESULTS» TAB - SUB-TAB «RECOGNITION RESULTS»

This sub-tab is available in all operating modes. The last hundred recognition events and related pictures of license plates shows in the table. The corresponding full-size snapshots from the camera lies in the bottom line of the window in a minimized form. It can be stretch with the left mouse button up to the desired size.

You can sort the table by any column in the direction of increasing or decreasing results, except "Photo" and "Technical data".

Double-click on the recognized number image (column "Number plate") will take you to the vehicle database: the tab "Car database", sub-tab "Vehicle"([p.4.8.1](#)).

The descriptions of the direction icons ("Direction" column) situated in [p.5.3](#).

4.6.2 SUB-TAB «GROUPED BY NUMBER»

No.	Group	Access	Duration	Owner	Number plate	Date	Photo	Direction	Passage	Channel/Zone/Checkpoint
5					30PVRH	11.09.2015 17:21:34.801		Attempt to enter		1/1/1
						11.09.2015 17:21:35.137		Entry		1/4/1
						---	No available data		0/0	
						---	No available data		0/0	
6					44JGRL	11.09.2015 17:21:31.939		Attempt to enter		1/1/1
						11.09.2015 17:21:32.548		Entry		1/4/1
						---	No available data		0/0	
						---	No available data		0/0	

PICTURE 27: «RESULTS» TAB - SUB-TAB «GROUPED BY NUMBER»

This sub-tab is available only in "Checkpoint" and "Parking" operating modes. It contains one hundred of the last recognized license plates, and four related events for each one.

In each line of the event provides a snapshot only of the license plate, which serves for the recognition and analysis, service information about the vehicle passage direction and the checkpoint crossing result, the checkpoint number, date and time of the event. The last recognized event has the corresponding full-size snapshot from the camera. It situated on the bottom line of the window in a minimized form. And can be stretch with the left mouse button up to the desired size.

The table sorted in the sequence of license plates recognitions. You cannot resort it.

Double-click on the recognized number image (column "Number plate") will take you to the vehicle database: the tab "Car database", sub-tab "Vehicle" (p.4.8.1).

The descriptions of the direction ("Direction" column) and passage ("Passage" column) status icons situated in p.5.3.

4.6.3 SUB-TAB «PARKINGS»

A "Parkings" sub-tab is available only in "Parking" operating mode and used for monitoring and management the already created and configured parking areas (p.4.9.3.5). It have separate blocks of detailed and summarized information:

Parking selection

Filters block

Date	Owner	Group	Plate number	Checkpoint	Duration	Passage	Parking
2015.12.09 12:51	1	AI029SEM	AI 0296 EM	1	1 03:29	Passed success	1
2015.12.09 12:54	1	AA3319BM	AA 3318 BM	1	1 03:26	Passed success	1
2015.12.09 12:55	1	CH6961AD	CH 6961 AO	1	1 03:24	Passed success	1
2015.12.09 16:32	1	AI029SEM	AI 0296 EM	1	23:49	Passed success	1
2015.12.09 16:35	1	AA3319BM	AA 3318 BM	1	23:44	Passed success	1
2015.12.09 16:37	1	CH6961AD	CH 6961 AO	1	23:43	Passed success	1
2015.12.09 16:40	1	AI6116BB	AI 6116 BB	1	23:40	Passed success	1
2015.12.09 16:42	1	AA8753BK	AA 8753 BK	1	23:38	Passed success	1
2015.12.09 16:43	1		AA 0331 HE	1	23:37	Passed success	1
2015.12.09 16:48	1		AA 4995 HI	1	23:32	Passed success	1
2015.12.09 16:48	1		AA 0878 HP	1	23:31	Passed success	1
2015.12.09 16:55	1	AI699DCE	AI 6996 CE	1	23:25	Passed success	1
2015.12.09 16:59	1		AI 3324 BH	1	23:21	Passed success	1
2015.12.09 17:10	1		AA 5608 AM	1	23:10	Passed success	1

Summarized information block

Category	Count
Total on parking	46
Allowed	30
Violators	15
Unknown	13
Staff	14
Clients	18

Event screenshot

Detailed information block

PICTURE 28: «PARKINGS» SUB-TAB

4.6.3.1 PARKING SELECTION WINDOW

In the parking selection window, you can specify to demonstrate information about all of NumberOk parking areas together or each registered parking area separately.

4.6.3.2 DETAILED INFORMATION BLOCK

Detailed information block gives details about each car located in the selected parking lot. Rows are dynamically updates when cars entering and leaving. The columns contain information:

- Data - Calendar data of vehicle entry to the parking lot;
- Owner - Vehicle owner data;
- Group - The name of the group, the recognized number from;
- Plate number - Recognized license plate number of the vehicle;
- Checkpoint - Vehicle entry checkpoint;
- Duration - Time of residence the car in the parking lot, updated every 20-30 seconds. Displayed in the format: HH: MM: SS, if it is less than a minute, HH: MM - if the car parked less than a day, and DD_HH: MM - if the time exceeds 24 hours;
- Passage - The permission for checkpoint crossing: Passed success - passage permitted, Violator - passage violated. For example: passage of cars from denied group or at the prohibited date/time. The "re-entry" cars are counts as violators. Their exit was not recognized and they are still listed in the database as "stays in the parking lot";
- Parking -The parking area identificator where the vehicle situated.

For manual data correction of cars, that presents at the parking area you should right-click on the detailed information block and choose one of the two menu items:

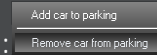

- **Add car to parking** - add one more car to the parking lot. Clicking this button opens a form for car injection to parking. It has positions to fill:
 - Parking area number;
 - Full license plate number;
 - License plate number country;
 - Owner data;
 - The NumberOk group that rooms this license plate;
 - Checkpoint, crossed to enter parking area;
 - Date and time of parking area entering.
- **Remove car from parking** - delete the car parking record in the line where menu called. Removing process needs the additional confirmation in the warning window.

PICTURE 29: ADD CAR TO PARKING LOT WINDOW

4.6.3.3 SUMMARIZED INFORMATION BLOCK

Summarized information block contains summary data about the cars that are in the selected parking areas. It contains items:

- **Total on parking** - number of vehicles parked on the area/areas;
- **Allowed** - amount of vehicles that crossed checkpoints without access rights violations;
- **Violators** - amount of vehicles that crossed checkpoint with access violation or cars with «Re-entry» status;
- **Unknown** - amount of cars not in groups, assigned to selected parking areas;
- And separate strings for all groups, assigned to selected parking areas.

Total results	
Total on parking	45
Allowed	30
Violators	15
Unknown	13
Staff	14
Clients	18

PICTURE 30: PARKING SUMMARIZED INFORMATION BLOCK

Each row shows the number of cars at the parking territory. It dynamically updated when cars passage the checkpoints linked to the parking area. The sum of «Allowed» and «Violators»; the sum of «Unknown» and cars in all other groups, should be equal to the «Total on parking» string value

4.7 «REPORTS» TAB

4.7.1 SUB-TAB «RECOGNITION RESULTS»

Filters block

Report generate button

Date/Time	Channel	Zone	Plate number	Owner	Group	Direction	Country
224 2016-01-11 14:27:03	3	2	RZ 0063C			Entry	Poland
225 2016-01-11 14:27:07	3	2	RZ 9182J			Entry	Poland
226 2016-01-11 14:27:10	3	2	RZE30R2			Entry	Poland
227 2016-01-11 14:27:13	3	2	RPZ 15653			Entry	Poland
228 2016-01-11 14:27:16	3	1	RZ 4033G			Exit	Poland
229 2016-01-11 14:27:20	3	2	PLA 09823			Entry	Poland
230 2016-01-11 14:27:25	3	1	RZ 9182J			Exit	Poland
231 2016-01-11 14:27:29	3	1	RZ 3137G			Exit	Poland
232 2016-01-11 14:27:30	3	2	TBU9K57			Entry	Poland

Consolidated results block

Parameter	Total	Ch1/Z1	Ch1/Z2	Ch2/Z1	Ch2/Z3	Ch2/Z4	Ch3/Z1	Ch3/Z2
Number of cars	5536	16	55	1	14	72	2260	3089
Entered	3160	3	40		3	4	277	2835
Exited	2345			1			1986	258
Undetermined	131	13	15		11	68	17	7

Event screenshot

Export to *.xls format button

PICTURE 31: «REPORTS» TAB - SUB-TAB «RECOGNITION RESULTS»

In "Recognition results" tab generating of two types reports is possible:

- General reports - all recognition events, generated by the following filters:
 - By time period;
 - By group;
 - By checkpoint (for «Checkpoint» mode);
 - By channels and recognition zones;
 - By license plate number or part of license plate number;
 - By vehicle passage direction;
 - By description;
 - Consolidated reports - total amount of passed cars, grouped by channels/zones and passage direction.

After selecting all the required filters, click the button «Generate» to the right of the filter unit **to generate the report**.

The report generates as a table of events and as a block of consolidated results. All the summaries can be export in Microsoft Excel format files by clicking on the button in the lower right corner of the window.

Double click on the recognized license plate image (column "Number") adds it to the cars database and switch user to the sub-tab "Vehicle" of the tab "Car database" (p.4.8.1).

The descriptions of the direction ("Direction" column) status icons situated in p.5.3.

4.7.2 SUB-TAB «GROUPED BY EVENT»

Owner	Group	Plate number	Country	Duration	Date	Direction	Passage	Checkpoint	System ID
45		RZE2CV9	PL	22:05	11.01.2016 14:13:27	↓ Entry	Manual access allowed	2 / 4	1
						↑ Exit	No available data	No available data	1
46		RZ 5336H	PL	22:05	11.01.2016 14:13:45	↓ Entry	Manual access allowed	2 / 4	1
						↑ Exit	No available data	No available data	1
47		RZE 15FX	PL	22:05	11.01.2016 14:13:51	↓ Entry	Manual access allowed	1 / 2	1
						↑ Exit	No available data	No available data	1
48		RZ 9440F	PL	22:05	11.01.2016 14:13:57	↓ Entry	Manual access allowed	2 / 4	1
						↑ Exit	No available data	No available data	1
49		WB 1396A	PL	22:05	11.01.2016 14:14:07	↓ Entry	Manual access allowed	1 / 2	1
						↑ Exit	No available data	No available data	1
50		WB1396A	PL	22:05	11.01.2016 14:14:07	↓ Entry	Manual access allowed	1 / 2	1
						↑ Exit	No available data	No available data	1

Entry	Total	Exit	Total	Violators	Total
Attempted to enter	1	Attempted to exit	1	Violators	753
Entered	3461	Exited	2302	Occupied	
New	3168	New	2095		
From database	294	From database	207		

PICTURE 32: «REPORTS» BLOCK - SUB-TAB «GROUPED BY EVENT»

Under this tab, you can generate reports about events, linked to recognized license plates.

After selecting all the required filters, click the button «Generate» to the right of the filter unit for report generation.

The report generates as a table of events grouped by the recognized license plates, and as a consolidated results block. All the summaries can be export in Microsoft Excel format files by clicking on the button in the lower right corner of the window.

It is worth noting that full-frame image from the camera is stored only for the last one of the recognized four events, linked to the license plate. You can open it by clicking anywhere on the appropriate string.

The descriptions of the direction (“Direction” column) and passage (“Passage” column) status icons situated in paragraph 5.3.

4.8 «CAR DATABASE» TAB

4.8.1 SUB-TAB «VEHICLES»

The screenshot displays the 'VEHICLES' sub-tab in the NumberOk software. The interface features a top navigation bar with buttons for 'View', 'Results', 'Car database', 'Reports', and 'Settings'. A 'Filters block' is positioned above a table that lists vehicle records. The table has columns for 'Country', 'Plate number', 'Owner', 'Group', 'Access', 'Duration', and 'Counter'. The 'Access' column contains status icons, and the 'Counter' column shows 'Not used' for all entries. At the bottom of the table, there are 'Add' and 'Delete' buttons, and 'Import/Export to *.xls format buttons'.

No	Country	Plate number	Owner	Group	Access	Duration	Counter
22	Poland	RZ6039F	RZ6039F	Staff	⊙	(0hour(s) 5minute(s))	Not used
21	Poland	RZELX02	RZELX02	VIP	⊙	(0hour(s) 5minute(s))	Not used
20	Poland	RZ1331E	RZ1331E	Staff	⊙	(0hour(s) 5minute(s))	Not used
19	Poland	WE277EM	WE277EM	VIP	⊙	(0hour(s) 5minute(s))	Not used
18	Poland	RZ33303	RZ33303	Staff	⊙	(0hour(s) 5minute(s))	Not used
17	Poland	RJS42V6	RJS42V6	VIP	⊙	(0hour(s) 5minute(s))	Not used
16	Poland	RZEHM32	RZEHM32	Staff	⊙	(0hour(s) 5minute(s))	Not used
15	Poland	RZ6824J	RZ6824J	VIP	⊙	(0hour(s) 5minute(s))	Not used
14	Poland	KTA47744	KTA47744	VIP	⊙	(0hour(s) 5minute(s))	Not used
13	Poland	RZ7240F	RZ7240F	VIP	⊙	(0hour(s) 5minute(s))	Not used
12	France	BC027CQ	BC027CQ	Staff	⊙	(0hour(s) 5minute(s))	Not used
11	Poland	RZ82446	RZ82446	VIP	⊙	(0hour(s) 5minute(s))	Not used
10	Poland	RZ1757G	RZ1757G	VIP	⊙	(0hour(s) 5minute(s))	Not used
9	Poland	RJA34580	RJA34580	Staff	⊙	(0hour(s) 5minute(s))	Not used
8	Poland	RZ0762F	RZ0762F	VIP	⊙	(0hour(s) 5minute(s))	Not used
7	Poland	RLA00094	RLA00094	VIP	⊙	(0hour(s) 5minute(s))	Not used
6	Poland	RZETJ06	RZETJ06	Staff	⊙	(0hour(s) 5minute(s))	Not used
5	Poland	WE380FA	WE380FA	VIP	⊙	(0hour(s) 5minute(s))	Not used
4	Poland	RZ92879	RZ92879	Staff	⊙	(0hour(s) 5minute(s))	Not used
3	Poland	RZE4160	RZE4160	VIP	⊙	(0hour(s) 5minute(s))	Not used

PICTURE 33: - «CAR DATABASE» TAB - SUB-TAB «VEHICLES»

Under this tab, you can add cars and bind them to pre-defined groups. User can select the country and enter the corresponding license plate template. NumberOk will check the template correctness and highlight it by the red when an error took place.

User can add and delete vehicles license plate numbers by add/delete buttons if he is authorized to make this operation. Each license plate number has data of its access rights (column Access), time spent in the parking lot (column Duration) and the number of entries to the parking area (column Counter). You can control the data demonstration in the table via the block of filters by the country, number, owner and group.

The user can also export and import the list of vehicles to/from Microsoft Excel format files. The example of such document is presented in annex (p.7.2).

The descriptions of the access ("Access" column) status icons are situated in paragraph 5.3.

4.8.2 SUB-TAB «GROUPS AND ACS»

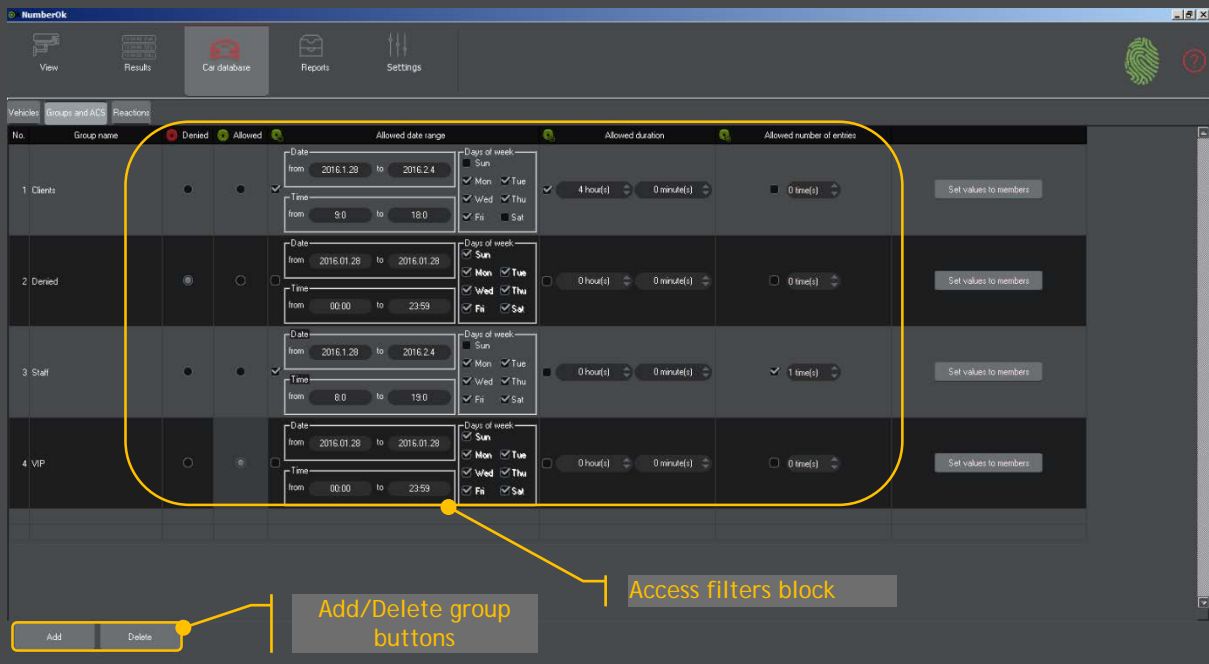

PICTURE 34: «CAR DATABASE» TAB - SUB-TAB «GROUPS AND ACS»

Use this tab to create, delete and edit vehicles groups, configure the settings for Access Control System in the "Checkpoint" and "Parking" modes.

Setting of the access rights for groups includes:

- **Denied** column - all group participants will have always denied checkpoint passage. Switching ON any of the columns for restricting access by date, duration time or number of entries clears the button of "Denied" column;
- **Allowed** column - all group participants will have always allowed checkpoint passage. Switching ON any of the columns for restricting access by date, duration time or number of entries clears the button of "Allowed" column;
- **Allowed date range** - configures access by the calendar date, time of day, day of the week. This block will work only when a checkbox in its left side is selected. Switched ON sub-blocks are combined with logical "AND", the access conditions must be met simultaneously: the date of passage should lie within the specified range of dates, day of the week correspond to an allowed and day time have to be within the specified range;
- **Allowed duration** column - it allows access to vehicles from the group when the total time of group participants, spent in the parking lot, does not exceed the specified. The unit works only when the tick in its left side is set ON;
- **Allowed number of entries** - allows passage of the group participants when the total number of their entries does not exceed the specified.

CAUTION! To apply changes to all group members after you configure access settings, be sure to click "Set values to members" button for each group.





Allowed setting of "**Denied**" OR "**Allowed**" columns, OR any combination of entries limitation items by date, duration time, number of entries. The switching **ON** any of the limitation items blocks the ability to switch **ON** "**Denied**" or "**Allowed**" columns.

Using a "**Denied**" or "**Allowed**" columns together with any limitation items is impossible.

The NumberOk software divides all vehicles license plate numbers into the two sets:

- License plates numbers, present in database. This array can be divided to different groups;
- License plates numbers, absent in database.

Tab 7: Vehicles access permissions by the groups

Icon	Name	Description
	Allowed	The entry always allowed for all vehicles from the group
	Denied	The entry always denied for all vehicles from the group
	Allowed on schedule	The entry allowed for all vehicles from the group in the described time and date range
	Allowed by entries number	The entry allowed for all vehicles from the group when the entries amount not exceeded (counted for every group separately)
	Allowed by duration	The entry allowed for all vehicles from the group when the duration time not exceeded

CAUTION! You can delete **only empty groups**, contains no car. For example, when you try to delete not empty group "VIP", the caution window will displayed:

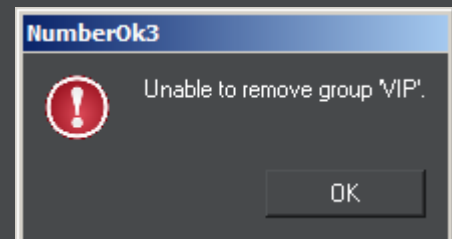

4.8.3 SUB-TAB «REACTIONS»

Sub-tabs "Reactions" serve to create the reaction on events in NumberOk system.

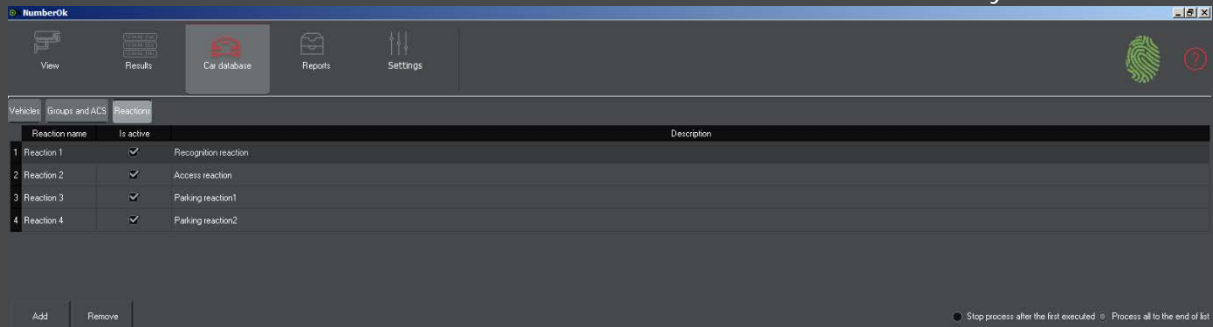

PICTURE 35: «REACTION» SUB-TAB WINDOW

4.8.3.1 CREATING AND ADJUSTING THE NEW REACTIONS

When you first open the "Reaction" sub-tab window it is empty and contains only the header of reactions table and add/delete reactions buttons. Clicking on the "Add" button opens a reaction creating form:

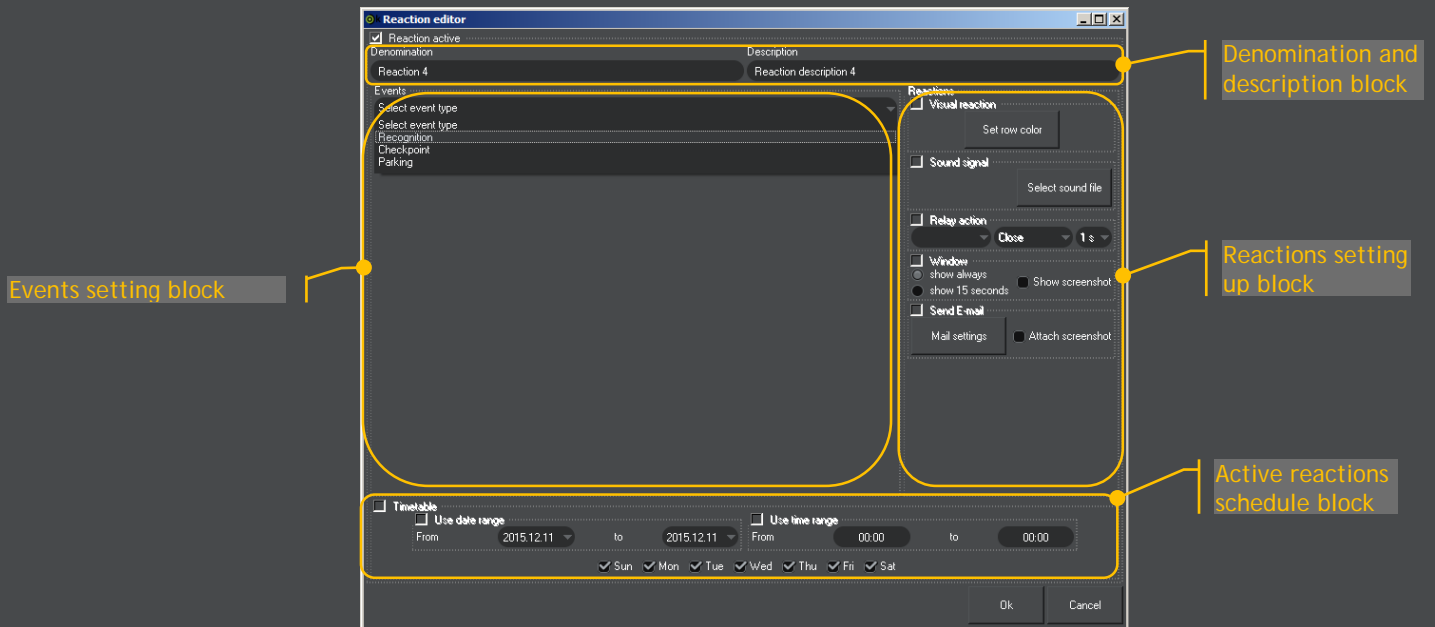

PICTURE 36: REACTION CREATION EDITOR INTERFACE

It includes the blocks for:

- Reactions descriptions and denomination;
- Events setting block;
- Reaction setting up block;
- Reactions schedule block.

To create a new reaction for the event it should be set a tick "reaction active" in the upper left corner of the reactions window editor. Without it, the editor tools will not be active. Then you have to perform sections [4.8.3.1.1-4.8.3.1.4](#) of this manual.

4.8.3.1.1 FILLING THE DESCRIPTION AND DENOMINATION BLOCK

Fill in the reaction name in the "Denomination" field and its description in the "Description" field of Descriptions and denominations block.

4.8.3.1.2 FILLING THE EVENTS SETTING BLOCK

Choose from the drop down list "Events" type of event and adjust its parameters. To switch ON each parameter class you have to select the checkbox in the appropriate line. Its implementation is united with logical "AND" - the reaction activation requires the simultaneous fulfillment of every active condition. There are three types of events:

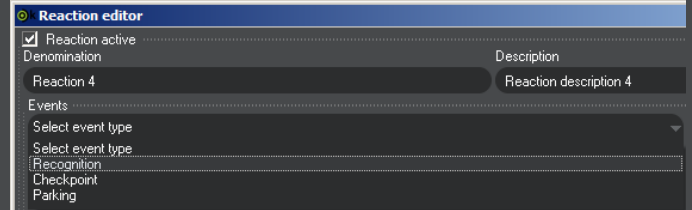

- **Recognition** - the fact of license plate number recognition by the NumberOk software. The choice of this type opens the recognize event settings form:



Fill it with the parameters that considered in the recognition algorithm operation. You can configure:

- **Plate number** - plate number which recognition will activate the reaction. To avoid false alarms, you can set a "Use country" checkbox and set the plate region. In this form, you can set plate number exactly or specify its patterns (regular expressions) to unite the set of numbers with similar parameters. More templates described in Appendix (p.7.3);
- **Select type of car or group** - select the relation of recognized number to NumberOk database. There are three options: "Out of DB" - there is no such license plate in NumberOk database; "Registered" - plate number is present in NumberOk database; "Group" - the plate linked to a group in NumberOk database. You can choose groups from a drop-down menu, marking one or more groups is possible;

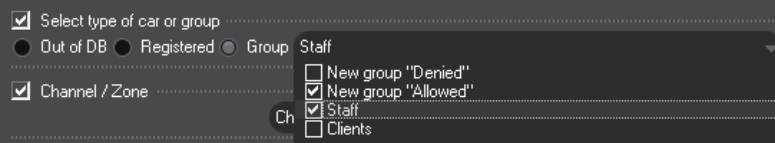

- **Channel/Zone** - select by the checkbox one or more zones, when the plates recognitions are expected;
- **Direction** - the direction of recognized number movement, determined by the movement in the frame. Possible options values: "Entry" - vehicle entering area; "Exit" - vehicle leaving area; "Undetermined" - the direction of movement could not be determined.

- **Checkpoint** - activity at one or more system checkpoints. The form of its configuration includes:

- **Checkpoint** - selecting one or more checkpoints, registered in NumberOk. Required items are checked;
- **Select type of car or group** - select the relation of recognized number to NumberOk database. There are two options: "Out of DB" - there is no such plate in NumberOk database; "Group" - the plate number linked to a group in NumberOk database. You can choose groups from a drop-down menu, marking one or more groups is possible;
- **Direction** - the direction of recognized plate number movement, determined by its movement in the frame. Possible options values: "Try entry" - marks the entry attempt; "Entry" - vehicle has entered area; "Try exit" - marks the exit attempt; "Exit" - vehicle left an area;
- **Access control** - passage authorization issued by Access Control System. Possible values: "Allowed" - Passage allowed; "Denied" - passage denied; "By date" - passage scheduled by access control system; "By entries count" - passage permitted by the number of entries to the territory; "By duration" - passage allowed by the vehicle "stay at the territory" time.
- **Parking** - an event on one or more parking areas of NumberOk system. Setup forms of event includes:

- **Parkings** - selection of one or more parking areas registered in NumberOk;
- **Select type of car or group** - select the relation of recognized number to NumberOk database. There are three options: "Out of DB" - there is no such license plate in NumberOk database; "Registered" - plate number is present in NumberOk database; "Group" - the plate linked to a group in NumberOk database. You can choose groups from a drop-down menu, marking one or more groups is possible;
- **Duration of stay on the territory** - set the permitted "stay at the territory" time for the car. You can adjust the "Duration>" - the maximum time spent at the territory, in hours and minutes. The reaction will be activated when the time exceeded volume; tick "Use range" activates the reaction if the spent at the territory time of the

car less than the specified in the "Duration<" in hours and minutes; tick "On timer" activates the reaction when the timer of license plate stays at the territory time reaches minimum or maximum values, regardless of the location of the vehicle: at the checkpoint or in the parking lot; tick "recognition" activates the reaction only after license plate recognition in the NumberOk system, when the time after "Entry" of the license plate exceeds the maximum or minimum values;

- Cars on territory - the reaction is activated when exceeding a specified number of cars at the territory ("Cars count>"); tick "Use range" activates the reactions when the number of cars in the parking lots is exceeds or equal the value in the "Cars count<" window.

4.8.3.1.3 FILLING THE REACTION SETTING UP BLOCK

In the Reactions setting up block, you can specify the actions to perform after the occurrence of certain events. Any manipulation in the block are only possible after type of event selecting in the events block. Reactions block does not depends on the type of event. Various responses united in the classes, the involvement of any of them performed by setting the appropriate checkboxes. Blocks actions united with logical "AND"/ It means: when the event will occurs, all selected and configured reactions will worked out. You can configure:

- Visual reaction - it paints line with the event in the results tables in the selected color. The color will set after clicking the "Set row color" button. Button will painted to this color too;
- Sound signal - plays the *.WAV format sound file;
- Relay action - one of three commands is sending to selected relay:
 - Open - open relay;
 - Close - close relay. You can set duration only for this command from the values: 1s, 2s, 3s, 4s, 5s, 10s;
 - Switch state - switch the relay state.
- Window - when the event occurs, the system opens a window with information about the event over the all Operating System windows. Possible options for the reaction duration:
 - Show always - windows opens until will be closed by operator. It is undesirable to use this option when often events are expected and operator will not be able to close them in a timely manner. Too many opened windows may crash the OS;
 - Show 15 seconds - popup window opens only for 15 seconds after the event occurs.

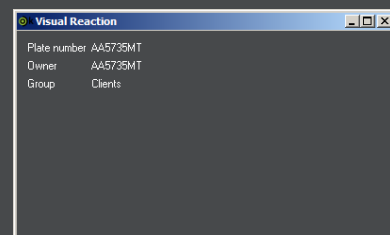
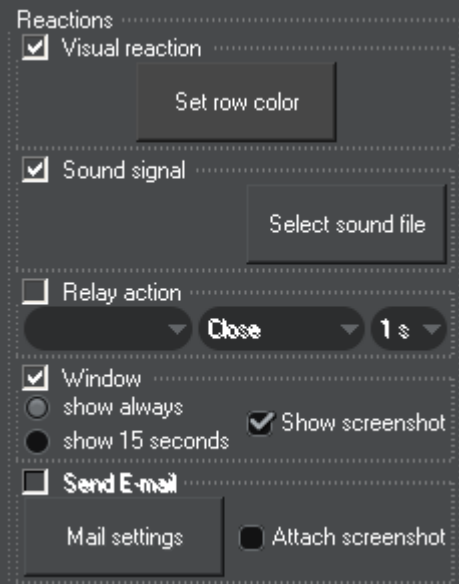

If you set "Show screenshot" tick, the picture from the associated camera will be placed in pop-up window:

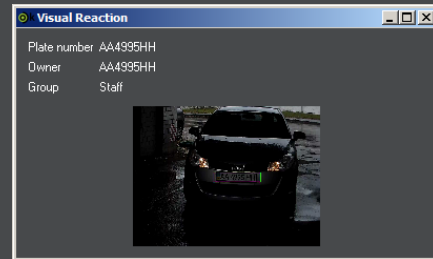

- To activate Active reaction schedule block you should select "Timeable" checkbox.

Timetable

Use date range Use time range

From 2015.12.11 to 2015.12.11 From 00:00 to 00:00

Sun Mon Tue Wed Thu Fri Sat

There you can schedule a reaction activity: enter a date range, specify days of the week and time of day, when reaction to the event will work.

Date, time and days of the week united with logical "AND", i.e. to activate the reaction it will require that the date, day of week and time of the event simultaneously fall within a predetermined range.

4.8.3.2 REACTIONS MANAGEMENT

You can edit or delete created and configured reactions in NumberOk system or increase their amount. Follow next steps from the window of sub-tabs "Reactions":

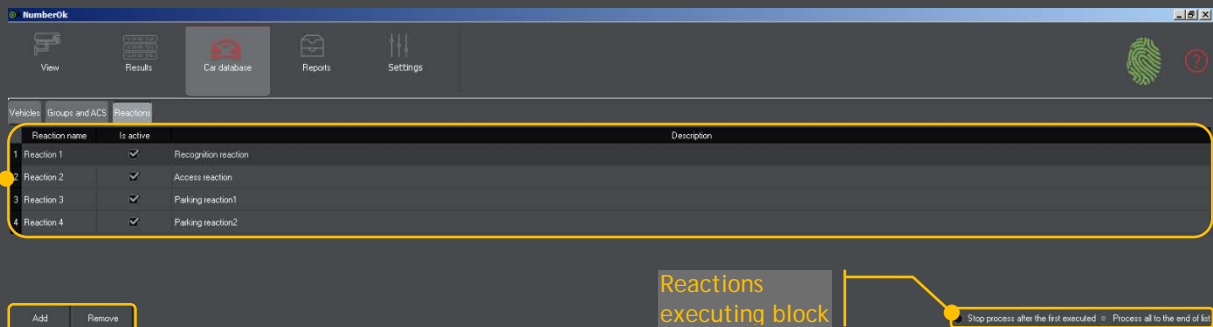

Created reactions list

Add/Remove reactions buttons

Reactions executing block

PICTURE 37: SUB-TAB «REACTIONS» - REACTION CONTROL WINDOW

Clicking on the "Add" button opens a new reaction editor. Its items described in the [p.4.8.3.1](#). New reaction appears in the table of created reactions with the appropriate name and description.

Column of ticks "Is active" in created reactions list, indicates the status of each reaction, these ticks are not clickable, their status changes in the reactions editor ([p.4.8.3.1](#)).

To change the existing NumberOk system reaction you need to double-click the left mouse button on the reaction name or on its description, but not tick activity. It will open reactions editor ([p.4.8.3.1](#)).

To remove one of the reactions you need to click the left mouse button anywhere on the reaction line and click "Remove" button.

CAUTION! Reaction removing event occurs without a warning message, restoration of deleted reactions not provided.

Reaction executing block - allows selecting one of the options:

- Stop process after the first executed** - The executing of any reaction stops the executing of other reactions with the same type events ("Recognition" or "Checkpoint" or "Parking"). Other type events reactions will be carried out free;
- Process all to the end of list** - Reactions executing process does not depend on its activity, they will be active until the corresponding checkbox is enabled.

4.9 «SETTINGS» TAB

4.9.1 SUB-TAB «GENERAL»

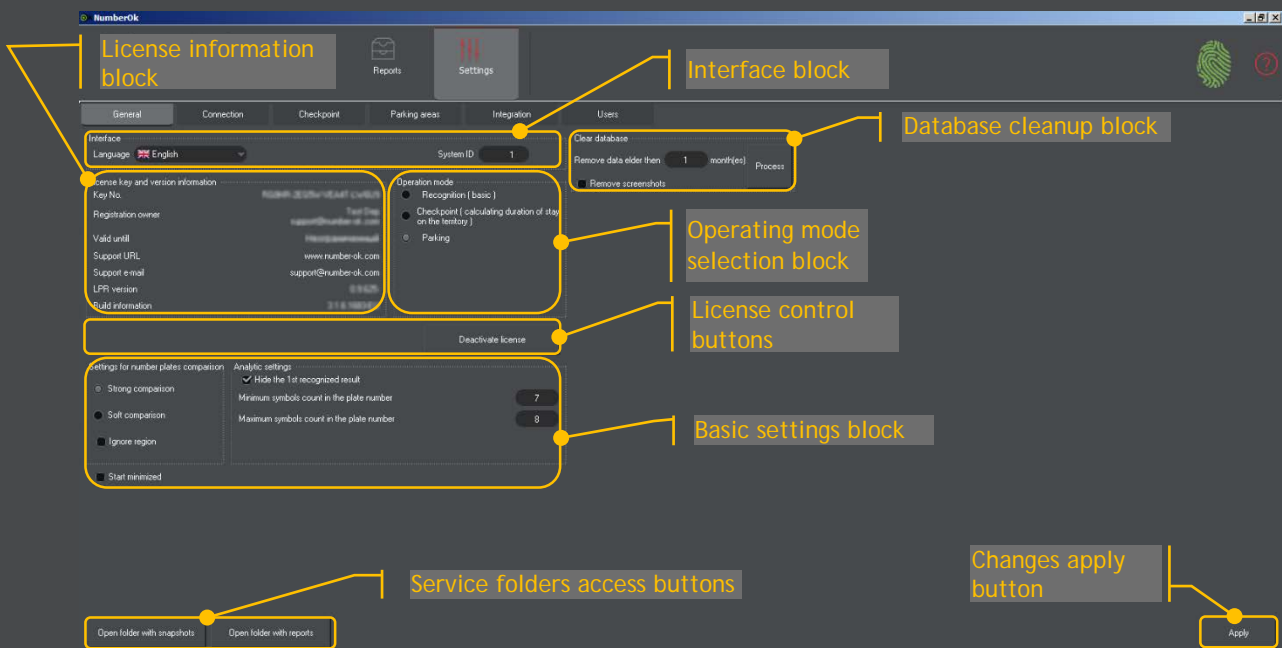

PICTURE 38: «SETTINGS» TAB - SUB-TAB «GENERAL»

There are five work areas:

1. **Interface block.** It contains interface language menu and system ID window.
2. **License information block.** It demonstrate:
 - License No;
 - Customer name;
 - NumberOk Technical support service contact information.

Situated below **License control buttons block** allows to deactivate current license or purchase full version of software (when demo-version used).

3. **Operation mode selection block** (see description in [p.4.2](#)). The set of settings sub-tabs depends on selected mode:
 - **Recognition mode (basic).** Sub-tabs of settings tools looks like:

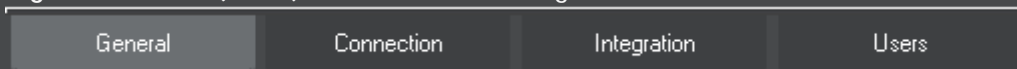

- **Checkpoint mode** - system recognize the license plates, controls access gates and deals with "stay at the territory" time management. Sub-tabs of settings tools looks like:



- **Parking mode** - NumberOk provides the set of tools for creating and managing one or several parking areas. Sub-tabs of settings tools looks like:



4. **Database cleanup block** designed to delete the accumulated data from the NumberOk database. Clicking on the "Process" button erases the data, earlier than deadline set. Its value calculated as a sum of the amount of days to the end of the current calendar month and the number of months indicated in the window "Remove data elder than".
5. **Basic settings block** allows:
 - Comparison customization with reference data base
 - **Strong comparison** - all recognized license plates in series stored as new;
 - **Soft comparison** - a single license plate in recognition series that differs in 1-2 characters from whole series stays ignored. **This setting is highly recommended for NumberOk in "Checkpoint" and "Parking" modes;**
 - **Ignore region** - the tick turns off region code recognition for license plates from Russia Federation;
 - Adjust templates for plate number recognition;
 - Launch NumberOk minimized to a system tray.

Left click on the data folders access buttons opens the directories with recognized images and exported reports. To set the changes still work after program restart, click "Apply" button in the left bottom corner of **General settings** window before leaving of sub-tab.

4.9.2 SUB-TAB «CONNECTION»

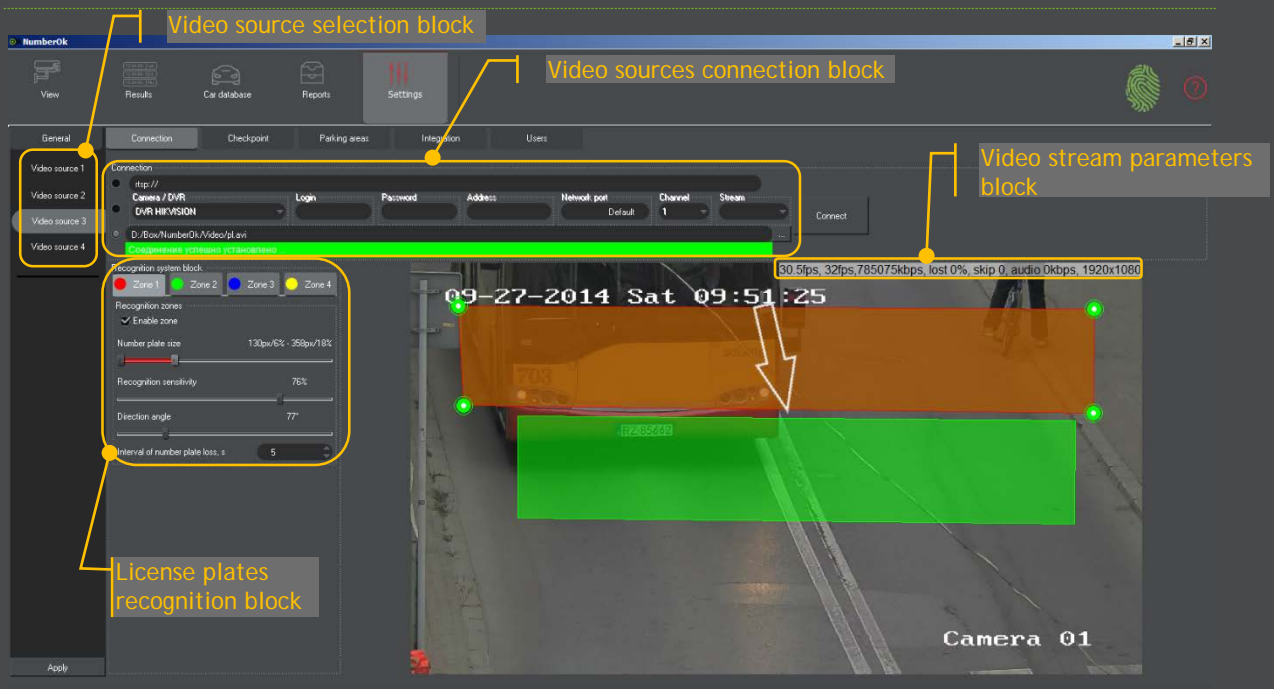

PICTURE 39: «SETTINGS» TAB - SUB-TAB «CONNECTION»

- Video source selection block;
 - Depending of purchased license type, **one**, **two**, **four**, **six** or **nine** channels can be available to the user. “Video source” means the camera (file) that can be connect to NumberOk software.
- Video sources connection block (p.4.9.2.1);
- Video stream parameters block -Video stream parameters are listed in one line separated by commas:
 - F_{recogn} - Real-time FPS (frames per second) that transferred to recognition module. This is a theoretical parameter, it depends on computer’s CPU power and ideally responds to $F_{\text{video}} = F_{\text{recogn}}$;
 - F_{video} - Amount of frames per second delivered by video source;
 - **Lost** - rate of data loss from video sources;
 - **Skip** - rate of missed (not captured) frames. When computer’s CPU is insufficient power the frames can be skipped (video signal will be unstable);
 - **Audio** - audio data traffic rate;
 - **Resolution** - resolution of video source.
- License plates recognition block - Parameters setting for license plates recognition block (p.4.9.2.2).

To apply your changes and save them after NumberOk restart, you have to press the “Apply” button in the lower left corner of the “Connection” sub-tab.

4.9.2.1 VIDEO SOURCES CONNECTION

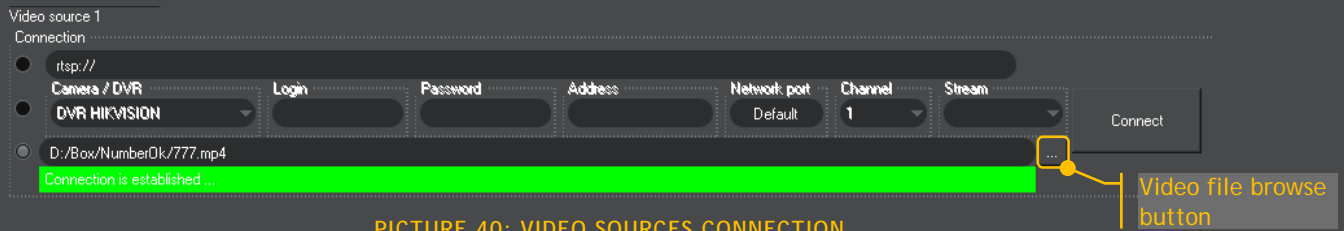

PICTURE 40: VIDEO SOURCES CONNECTION

NumberOk receives and decodes video streams in the next formats:

- Live 555 library:
 - MPEG_DECODER_TYPE_H264;
 - MPEG_DECODER_TYPE_MPEG4;
 - MPEG_DECODER_TYPE_JPEG;
 - MPEG_DECODER_TYPE_MXPEG;
- FFMPEG library:
 - AV_CODEC_ID_H264;
 - AV_CODEC_ID_MPEG4;
 - AV_CODEC_ID_HEVC.

NumberOK provides three types of connection:

1. Uniform connection via [RTSP protocol](#) (refer to examples in [p.7.1](#)). About 99% of IP cameras and most of DVRs supports RTSP protocol.
For example, we provide connection to Hikvision IP camera:
Rtsp://admin:12345@IP_address:554/, where
Admin - user name;
12345 - user password;
IP_address - camera address;
554 - RTSP port.
2. CAMERA/DVR - such video sources connected via SDK, provided by camera's or DVR's manufacturers. NumberOK supports the following brands:
 - DVR Hikvision;
 - DVR Dahua;
 - DVR NUVUS B series;
 - DVR LINIA;
 - DVR TVT;
 - DVR Praxis;
 - DVR NUUO;
 - DVR Partizan.

Text fields

 - Login - user name;
 - Password - user password;
 - Address - IP address;
 - Network port - port;
 - Channel -number of channel (camera);
 - Stream - number of video stream (main/secondary, 1/2/3 ...).
3. Local video files: In order to quick adjust application and test its functionality, user may use a local video files as video source. Local video files played in a cycle.

To link the video source you have to select connection type, enter its parameters and press "Connect" button.

4.9.2.2 RECOGNITION BLOCK SETUP

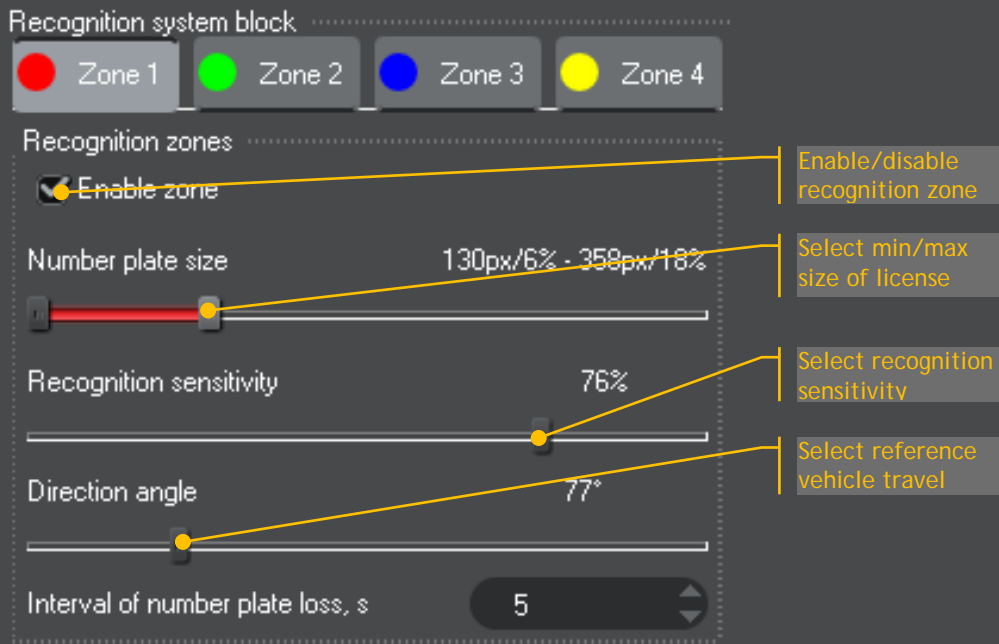

PICTURE 41: SETUP OF RECOGNITION BLOCK

To configure the license plates recognition with maximum accuracy you can adjust:

1. Recognition zones - the area of the video frame where NumberOk will recognize the license plates numbers. The user can specify the zone by moving the rectangle vertices with the left mouse button. Available the setting up to four zones. By default, no one zone enable.

The zone size had to provide maximum time of recognizable number being in zone. **It is highly recommended not to overlap recognition areas!**

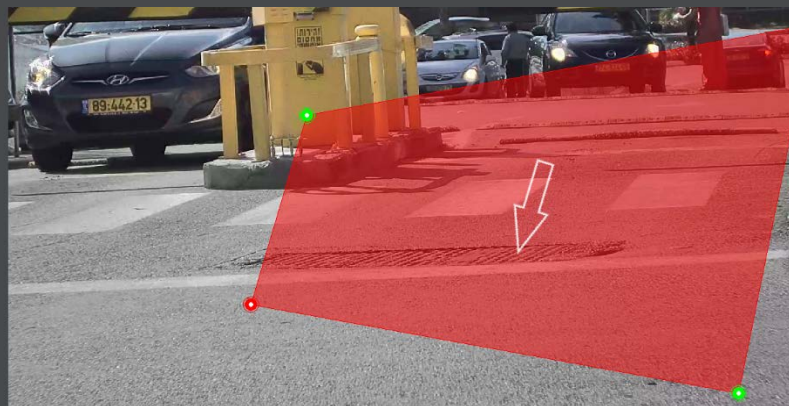

PICTURE 42: RECOGNITION ZONE SIZE EDITING

2. Number plate size - user may choose minimum and maximum size of license plate image in pixels. NumberOK will search the number plates in specified sizes range. Minimum size of number plate is 130 pixels, maximum - 1000 pixels. Default size is 130-300 pixels. The size of number plate can be determined by measuring screenshot

from the camera. You can also refer to “Technical data” of recognized plates in the “Results” tab (p. 4.6.1) using wide range, and set more narrow range after real sizes analyzing.

Date	Owner	Group	Number plate	Photo	Direction	Channel	Zone	Technical data	Country	Recognition sensitivity	Plate number size
11.09.2015 17:31:08			JS PX 61		Attempt to enter	1	1	23ms/270px/0.8/12/245°/NL		1	
11.09.2015 17:31:04			66THG1		Entry	1	1	36ms/196px/1.1/8/65°/NL			

PICTURE 43: SUB-TAB «RECOGNITION RESULTS» - TECHNICAL DATA

3. **Recognition sensitivity** (recognition accuracy) - every recognized license plate has its own accuracy rate. The higher image quality is - the higher is recognition accuracy. Accordingly, false number plates have lower accuracy rate. To exclude false number plate recognition it is essential to select such recognition sensitivity threshold that will be higher than false values and lower than real number plates. The value of recognition accuracy depends on the video stream quality. By default, the recognition sensitivity set to 50%. **Increase it for a more precise recognition to 65-70%**. The real values of recognized number plates are available in “Technical data” of recognized numbers in the “Results” tab (p.4.6.1).
4. **Direction angle** - Proper functioning of algorithm for detection of vehicle direction by movement of number plate in the frame (p.5.2.2) requires a thorough understanding of vehicle passage directions. This parameter determines reference passage direction. Its value lies within 0 -359°, in 1-degree increments. Use slider bar or scroll your mouse wheel to adjust the value. As you can see from PICTURE 43, the arrow always points to Entry. If the vehicle direction is same as the direction of arrow, the system will detect *Entry*. If passage direction is opposite to the arrow direction, the system will detect *Exit*.



PICTURE 44: REFERENCE VEHICLE DIRECTION

Setting the Reference passage angle "by eye" or by direction of the road marking may cause the mistake, **much more accurate** it is determined after analysis the “Technical data” of already recognized numbers (p.4.6.1).

4.9.3 SUB-TAB «CHECKPOINT»

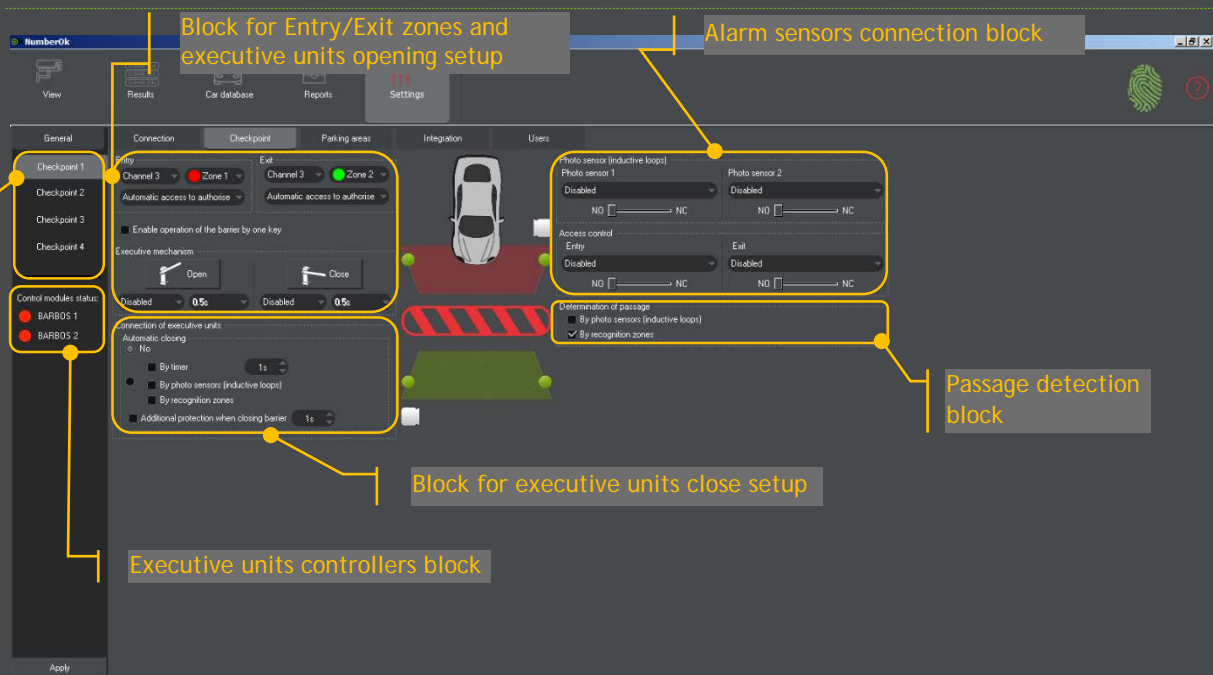

PICTURE 45: SUB-TAB «CHECKPOINT»

Sub-tab "Checkpoint" - available only in the "Checkpoint" and "Parking" operation modes of NumberOk software (p.4.2). It is intend for checkpoints configuration, and includes:

- Entry/Exit zones adjusting;
- Executive units connection;
- Adjusting algorithms for executive units open/close;
- Connection of entry detection algorithms.

Checkpoint configuring begins with selecting the desired item in the selector gearbox. Its state and configuration will show on the diagram in the center of the "Checkpoint" sub-tab.

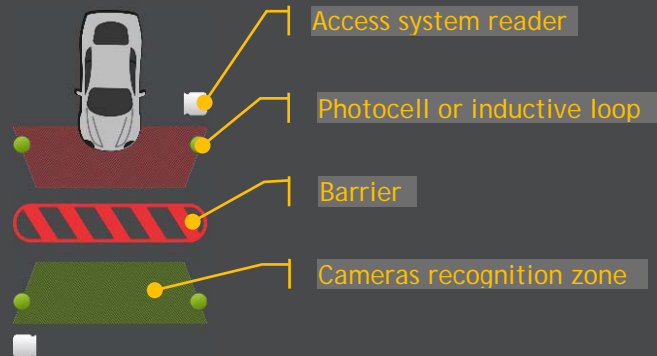

PICTURE 46: ICONS AT THE CHECKPOINT CHART

4.9.3.1 SETTING UP OF ENTRY/EXIT ZONES AND EXECUTIVE UNITS OPENING/CLOSING

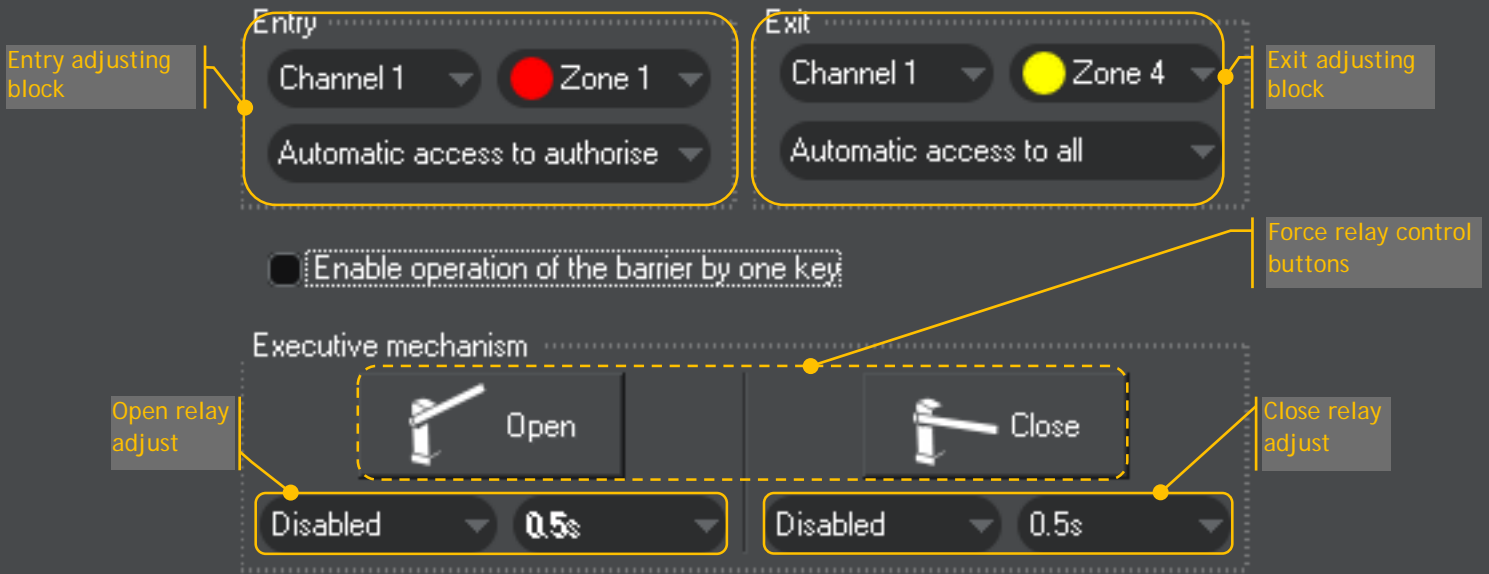

PICTURE 47: BLOCK FOR SETTING UP THE ENTRY/EXIT ZONES AND EXECUTIVE UNITS OPENING

This toolbox allows to adjust the entry and exit recognition zones and the actuators opening.

The entry and exit blocks serve to define the channel and a recognition area for each event, the algorithm for reaction on it. You can select only the areas, switched ON in the recognition block (p.4.9.2.2).

For bidirectional checkpoints (p.5.1.3), you have to select two detection areas (entry and exit) and enable the passage direction determination by adjacent recognition zones (p.5.2.3.2). For unidirectional checkpoints, the one detection zone is enough.

In the open and close relays settings blocks you need to specify the desired relay from the drop-down list of relays connected to the control module (p.3.3.1) They are responsible for the "open" and "close" commands (p.3.3.2), you need to select the duration of their acting.



PICTURE 48: DROP DOWN LIST FOR RELAY SELECTION

If the executive mechanism triggered by one relay and the checkbox "Enable operation of the barrier by one key" is set, the close relay section becomes passive. Only the unit open section remains configurable. The algorithm of events reaction offers three opening options:

- o Denied access to all - for everyone license plate number the barrier stay closed;
- o Automatic access to all - "Open" command will be generated for any recognized plate number. This mode **have to be set** when NumberOk operates in "Parking" mode;
- o "Open" command will generated only for recognized plate numbers from permitted groups (hen NumberOk operates in "Parking mode", this option **denied**);
- o Access all except denied - the command to executive units relay will be issued for any plates, except denied in the NumberOk SMB database (p.4.8.2).

4.9.3.2 BLOCK FOR EXECUTIVE UNITS CLOSE SETUP

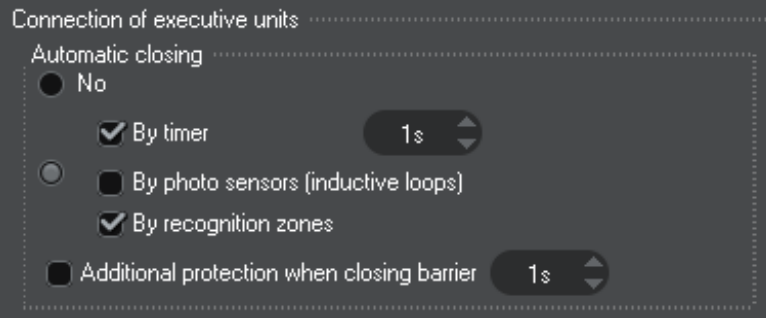

PICTURE 49: EXECUTIVE UNITS CLOSING SETUP

The next algorithms are available for executive units closing:

- **No** - The barrier/gates will close by checkpoint operator;
- **By timer** - "Close" command will issue after a specified time, the timer value range: 1 - 30 s.;
- **By photo sensors (inductive loops)** - "Close" command generates after sensors activation in the special sequence (p.5.2.3.1);
- **By recognition zones** - "Close" command generates after entry fact detection by cameras adjacent recognition areas (p.5.2.3.2).

You can set a pause for a barrier closing. It can be completely cancel at any time during the closing by activation of any alarm sensor- it generates the "Open" command.

4.9.3.3 ALARM SENSORS CONNECTION BLOCK

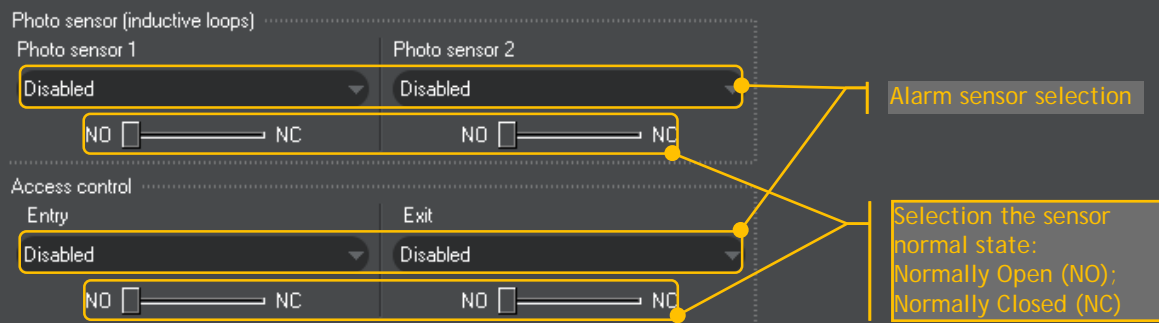

PICTURE 50: ALARM SENSORS CONNECTION

In this block user can select the alarm sensors connection (vehicle presence detectors and access system readers) and their initial state setting: Normally Closed (NC) or Normally Open (NO).



Several pairs of detectors are available for connection. Detectors provide the detection of entry and ensure closing of the barrier after the vehicle passage. Photo sensors or inductive loops can serve as the detection sensors. When the vehicle crosses photo sensor beam or stands within induction loop, the event will highlighted in **red** on the screen. If there is no any vehicle - the element will highlighted in **green**. When algorithm for detection of vehicle direction by detectors is triggered (the car passed through), two indicators on the detectors will illuminate in the direction the vehicle passage. It is also possible to connect alarm events from Access System Controller with "dry contacts" for confirmation the vehicle access rights by the access card. If this alarm input triggered, the event will highlighted at the chart in **green** color (PICTURE 46).

4.9.3.4 PASSAGE DETECTION BLOCK

The passage detection block offers two ways of event registration:

- By photocells (inductive loops) - the passage registered after triggering the physical sensors of the car presence in certain sequence ([p.5.2.3.1](#));
- By recognition zones - the passage registered after sequential license plate number recognition in the entry and exit adjacent areas ([p.5.2.3.2](#)).

4.9.3.5 SUB-TAB «PARKING AREAS»

To add a new parking area you need press the button "Add parking area" in the upper left corner of the screen , or right-click on the open field of the window and select "Add parking area": .

It opens a new parking setup panel. All subsequent panels will automatically scaled and positioned to fill all screen area. The panels consist of the following blocks:

- **Parking name** - automatically assigned when creating a new parking area. You cannot change it, deleting the other parking area does not affect the numbering;
- **Places in this parking area** - the maximum number of cars that can enter a parking zone at the same time;
- **Unregistered cars access parameters** - reserved slots, access data and reactions for detection the cars from groups not assigned for this parking;
- **Assigned cars groups** - a list of vehicles groups from the NumberOk database ([p.4.8.2](#)), assigned to this parking area. The group settings contains number of places and access parameters for group members;
- **Checkpoints** - a list of pre-installed checkpoints for vehicles entry and exit to/from this parking area.

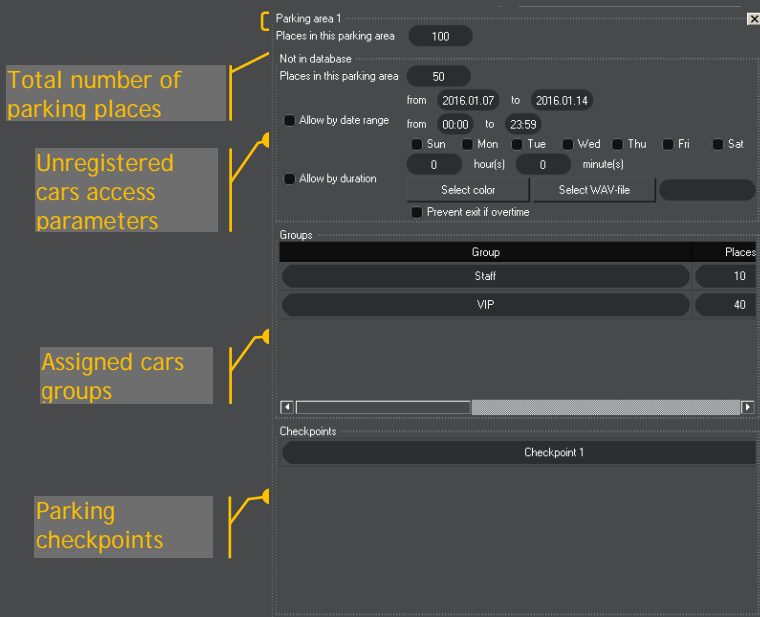

PICTURE 51: PARKING AREA SETUP PANEL

CAUTION! The barrier control algorithms for parking areas checkpoints have to be set to "Automatic access to all" values for entry and exit directions. Access rights in "Parking" mode determined only by parking settings. It has priority over checkpoints.

4.9.3.6 UNREGISTERED CARS ACCESS PARAMETERS

You can modify the next parameters in a Not in database block:

- **Places in this parking area** - the number of parking slots, can filled by the cars are not included in any of the groups assigned to this parking area. Its amount cannot exceed the difference between the total number of parking spaces and the amount allocated to the groups in this parking lot. If this parameter is equal to zero, the access to unregistered cars is denied. Filling all the parking spaces for unregistered cars will deny the entry for more such vehicles until one of slots became empty;
- **Allow by date range** - setting the tick enables the access limitation by date, time of day and day of the week block. Dates and times typed from the keyboard, days of the week selected by checkboxes. If "Allow by date range" tick not set, none of this parameters are considered;
- **Allow by duration** - set the tick and specify the number of hours and minutes the car may stay in the parking lot. Since its entry into the territory, the duration timer would be start. An "Exit" event should be registered to this number before the time of its stay in the territory exceeds the allowed. The duration time for each unregistered license plates carried out individually. If the box is not checked, the duration time of the license plate is not considered;
 - **Reaction buttons block** allows to setup painting the unregistered car string in parking table with selected color and playing selected WAV file, when the unregistered license plate exceeds allowed "stay in the parking area" duration time;
 - **Prevent exit if overtime** - setting this tick denies the barrier opening for **both registered and unregistered** vehicles trying to exit the parking area with exceeded the allowed "stay in the parking area" duration time.

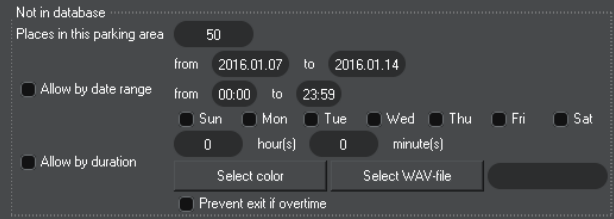

PICTURE 52: UNREGISTERED CARS ACCESS PARAMETERS

All items of the **Unregistered cars access** block combined with logical "OR". When one of them calculated entry deny for any unregistered license plate, this plate will move to the "Denied" category. The checkpoint passage for the car with this license plate will automatically denied and required operator intervention.

4.9.3.7 ASSIGNED TO PARKING GROUPS

- Setting up groups for each parking lot starts with mouse right-click on the **Groups** block and pressing "Add Group" button:
- The group's selection and parking places capacity setting window will appears in the **Groups** block. User can set the allowed amount of parking spaces in the parking lot for it. Clicking on the name opens a drop-down list of registered license plates groups:
- You have to select one of them. While one of the existing groups not selected, another group adding window will not available;



- Type the amount of parking spaces for this group in the parking lot. It should be a positive integer that does not exceed the total number of parking places;
- Right-click on an already created group opens an expanded menu where you can add another group or delete the previously created:
- For created groups you could slide adjusting table to the right to reach its time limit and reaction settings columns;

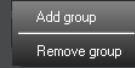

- Time limit columns contains Use time limit checkbox and Time limit settings;
 - Selecting a Use time limit checkbox enables reactions, when duration time for cars from group will be exceeded;
 - In a Time limit column you can set the allowed duration time for license plates from adjusted group;

Places	Use time limit	Time limit		Overtime row
30	<input checked="" type="checkbox"/>	0 hour(s)	0 minute(s)	
30	<input type="checkbox"/>	000:00		

- Reactions columns allows to setup system reaction for duration timeout of every groups of vehicles;
 - Overtime row color paints the parking table rows with timed out cars in the selected color;
 - Overtime periodic sound allows to select *.WAV file, will played when any car of this group exceeds groups duration time.

Time limit	Overtime row color	Overtime periodic sound
000:00	transparent	
000:00	<ul style="list-style-type: none"> slategray slategray snow springgreen steelblue tan teal thistle tomato 	

4.9.3.8 PARKING AREA CHECKPOINTS

- In Checkpoints block you can link pre-registered and configured in the NumberOk system checkpoints to the parking area. Simply right-click on the block and select the "Add checkpoint" button:



- A left-click in the appears window opens the dropdown list of NumberOk checkpoints available for selection:

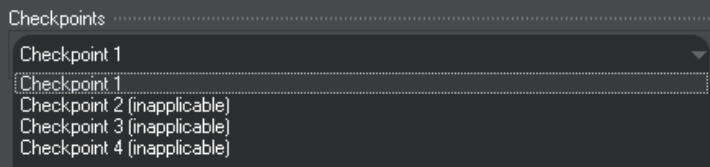

- Right-click on an already attached to the parking lot checkpoints opens the menu for add a new or delete current checkpoint:

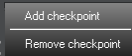

- After setting groups and checkpoints, the parking lot starts immediately. Watching the vehicles in it, managing their presence in the parking area are possible from the Parkings" sub-tab of the "Results" tab (p.4.6.3).

4.9.4 SUB-TAB «INTEGRATION»

4.9.4.1 TCP SERVER

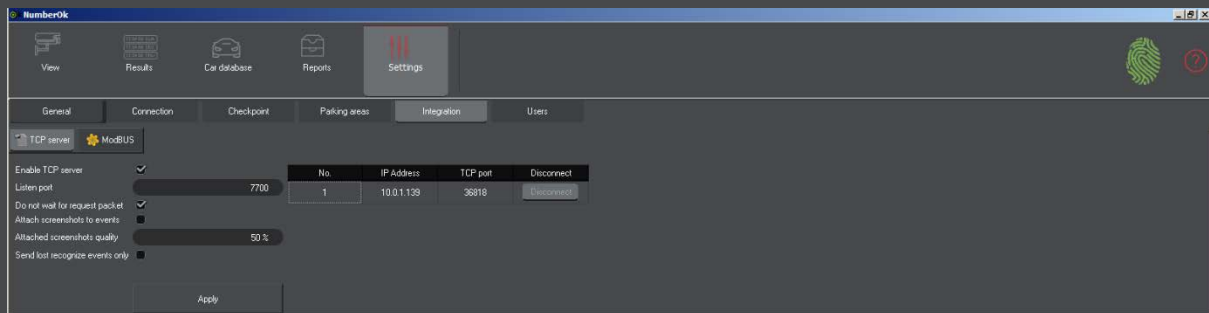

PICTURE 53: SUB-TAB «INTEGRATION» - TCP SERVER ADJUST

In this sub-tab window, you can tune the NumberOk integration with external applications via TCP. Thus, NumberOk acts as a server. An external application connects to it through the selected port and receives information about all recognition events. The messages are sending no more frequently than two times per second.

TCP server enabled by setting the checkbox "Enable TCP server". Its port is specified in the "TCP server port". NumberOk supports up to four connections, installed channels reflected in the table in the window center. The table shows the IP address and port of the connected applications. It is possible to disable each connection separately by clicking on the "Disconnect" button.

No.	IP Address	TCP port	Disconnect
1	10.0.1.139	36818	Disconnect

PICTURE 54: «SETTINGS» TAB- SUB-TAB «INTEGRATION» - CONNECTED APPLICATIONS

The systems may have preliminary connection (after connection is established, preliminary «request-response» will be sent from the systems and only after that the event will be transferred) or not (the recognition events are sent immediately after the connection is established). The server mode is set by selecting "Do not wait for request packet".

The packets of the transmitted information include text events and images of vehicles with recognized numbers, when a checkbox "Attach screenshots to events" is set. The picture quality is specified in the "Attached screenshots quality".

Checking the box "Send lost recognize events" means disabling the transmission of "raw" recognition results for each license plate number. Only analyzed and confidently detected information packages will be given to external applications during the "Interval of number plate loss" period (p.4.9.2.2). It allows to reduce outgoing traffic.

All changes to the settings you can save by pressing "Apply" button at the window bottom.

4.9.4.2 CONTROL MODULES CONNECTION VIA MODBUS PROTOCOL

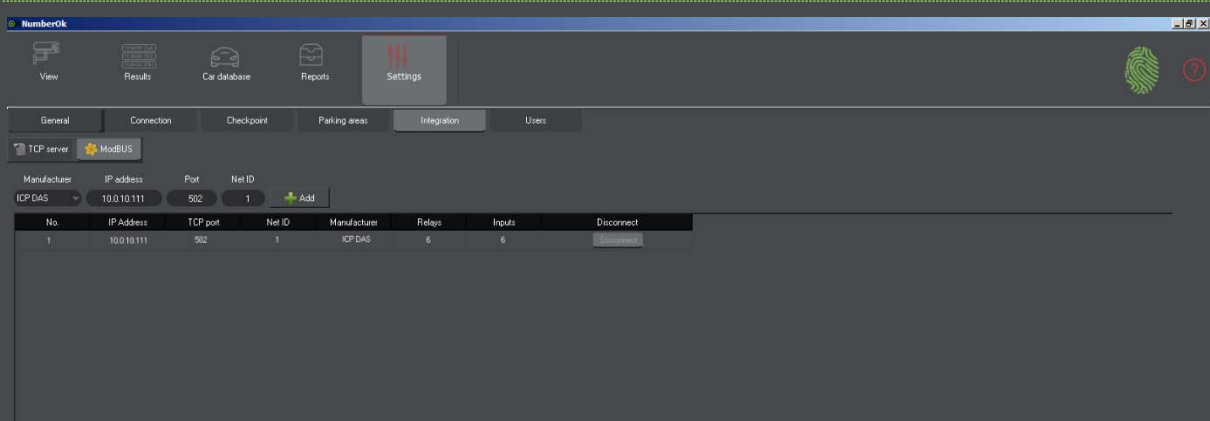

PICTURE 55: SUB-TAB «INTEGRATION» - MODBUS SETUP

NumberOk system can work with the executive devices control modules via ModBUS protocol. To connect the management module select its manufacturer (ICP DAS, Barix AG, Custom) from the dropdown list.

For the first two vendors it is enough to enter IP address, device port, ModBUS identifier "Network ID" and press the "Add" button.

If you select Custom manufacturer, you can connect to NumberOk any device that runs ModBUS protocol and have ModBUS digital Input and Output count registers.

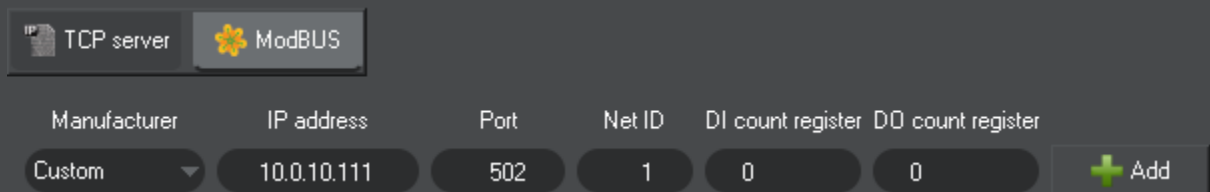

PICTURE 56: CUSTOM MODBUS MODULE SETUP

User have to enter in according to docs next values:

- IP adress (IP adress field);
- Device port (Port field);
- ModBus identifier (Net ID field);
- Input count register (DI count register field);
- Output count register (DO count register field).

For debug simplifying the NumberOk pack includes utility to dump the **not equal to zero** registers of ModBUS modules. The utility run in the command line in the format: DumpModBus.exe IP NetID, where:

IP - IP address of the ModBUS device;

NetID - the net ID in the ModBUS.

If the connection is successful, the connected module record will added to the table. You can simultaneously connect up to three ModBUS devices.

4.9.5 SUB-TAB «USERS»

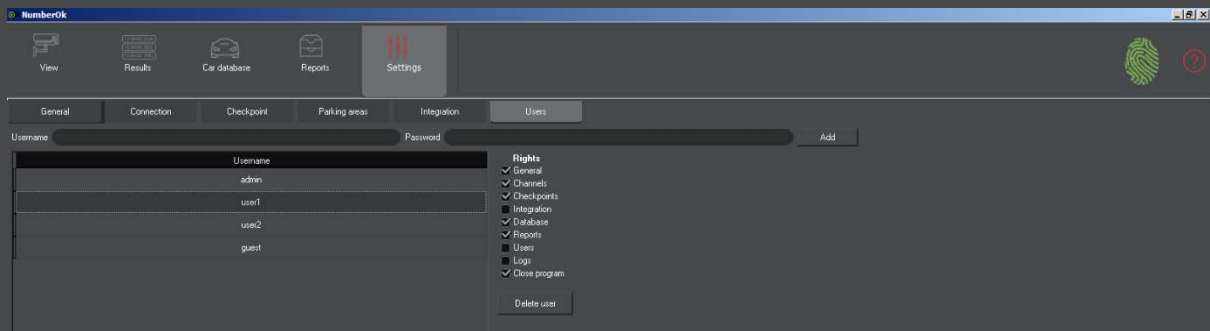

PICTURE 57: «SETTINGS» TAB - SUB-TAB «USERS»

Use this tab to set access rights for users to manage and use system functions. You can limit created accounts in the available tools by setting the appropriate checkboxes:

- General - sub-tab «General» management;
- Channels - sub-tab «Connection» management;
- Checkpoints - «Checkpoint» sub-tab parameters adjust;
- Integration - data change in «Integration» sub-tab;
- Database - «Car database» sub-tab management;
- Reports - checkbox lack means only the view of «Recognition results» sub-tab in tab «Reports»;
- Users - opens the access to sub-tab «Users» management: creating, deleting and managing of users rights;
- Logs - sub-tab «Integration» management;
- Close program - set the ability to close NumberOk software. If the user has not quit permissions, he will not be able to close NumberOk by the Windows GUI tools (clicking the "x" in the upper right corner of the window, double click in the upper left corner of the window, from the taskbar context menu).

If you create separate user accounts in the NumberOk system, be sure first to create the **user with maximum rights** for configuration and tuning the system (administrator). Only then, try to add limited accounts, to prevent a situation with no accounts permitted to configure the sub-tabs "Users" or quit the NumberOk program.

4.9.5.1 USERS AUTHENTICATION IN NUMBEROK SOFTWARE

To log into a previously created account you need to click the left mouse button on a red stylized image of the fingerprint, located in the top right corner of the NumberOk window.

Then you will see fields to input username and password. Upon correct authentication, i.e. the entry existing in NumberOk username and its corresponding password, the fingerprint will repaint in green color. Next click on the authentication button will log the current user out of NumberOk. The sign will again turns red.

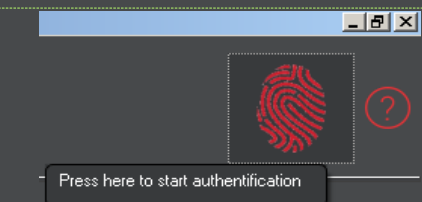

PICTURE 58: USER AUTHENTICATION BUTTON

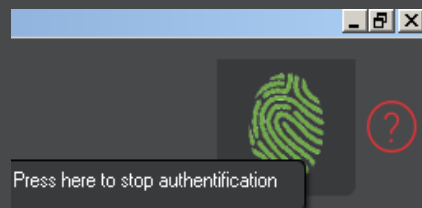

PICTURE 59: BUTTON AFTER SUCCESSFUL USER AUTHENTICATION

5 LEGEND, TERMS AND ALGORITHMS

5.1 CHECKPOINTS TYPES

5.1.1 ONE-DIRECTIONAL CHECKPOINTS WITHOUT ENTRY CONFIRMATION

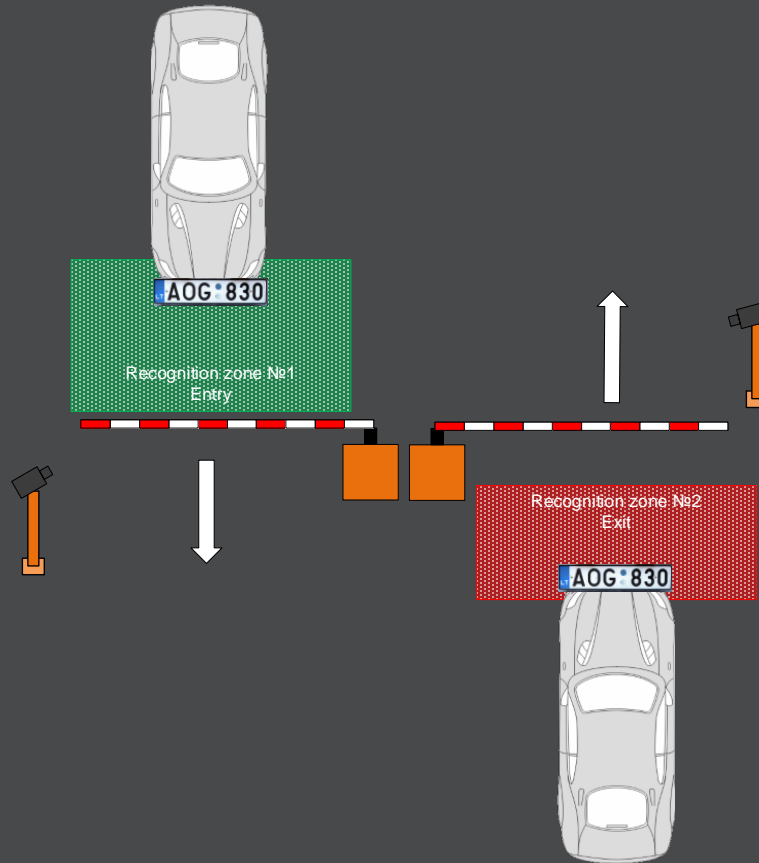

PICTURE 60: CHART OF TWO THE ONE-DIRECTIONAL CHECKPOINTS WITHOUT ENTRY CONFIRMATION

A checkpoint calls "one-directional" if the vehicles can pass it only in one direction (leaving or entering). Therefore, such checkpoint requires only one recognition area to manage the vehicles entry or exit.

The algorithm of passage direction identification in the one-directional checkpoint without passage confirmation is the next:

- Basic is the recognition of the travel direction by plate number in the frame;
- If the travel direction was not determined, it can be compute by the sequence of plate number detections in several recognition areas. i.e. there should be more than one zone.

The possible result of the algorithm:

Entry



Exit



The checkpoint barrier opens immediately after plate number recognizing, i.e. when the event "Entry attempt", occurs. Barrier closes by a timer or by the operator in manual mode. The **passage violation monitoring** (the plate number has denied entry, but it drove) is **impossible**. Valid passage value:



Acces automatically denied



Opened by user



Acces automatically allowed



Opened by card

5.1.2 TWO OF ONE-DIRECTIONAL CHECKPOINTS WITH ENTRY CONFIRMATION

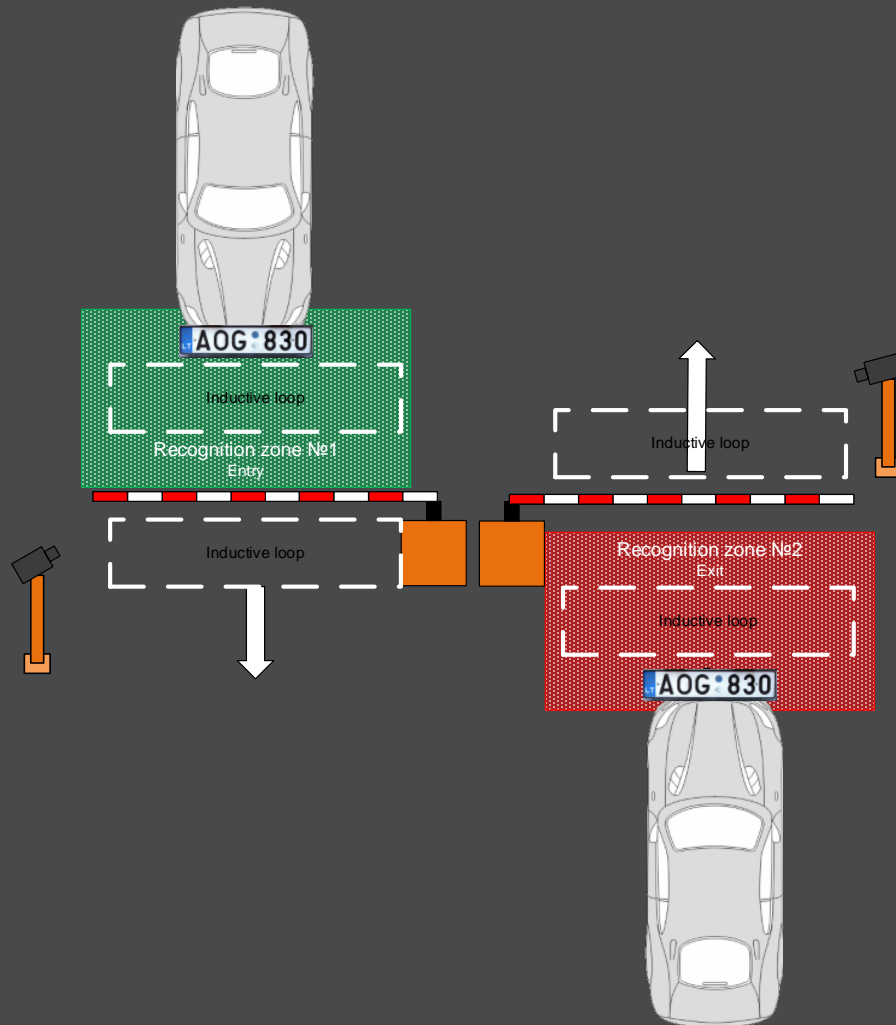

PICTURE 61: CHART OF TWO THE ONE-DIRECTIONAL CHECKPOINTS WITH ENTRY CONFIRMATION

Vehicles passes one-way checkpoints only in one direction, calls "Exit" or "Entry". Respectively, only one recognition zone responsible for the entry or exit.

In order to secure the passage confirmation, the additional alarm sensors (physical sensors for vehicle detection: photocells or inductive loops) implemented to checkpoint chart after the barrier.

The algorithm of the checkpoint passage direction determining is:

For motion direction determining are used the algorithms of travel direction determination by plate number motion in the frame, by recognition in adjacent zones (p.5.2.3.2) and by the alarm sensors (p.5.2.3.1).

Table 8: One-directional checkpoints - passage events legend















Icon	Event	Description
	Entry attempt	The event occurs when the vehicle detected in the Entrance recognition zone and algorithm of vehicle passage detection by movement of license plate generates status <i>Entry</i> or <i>Undetermined</i> . Standard situation.
	Entry	The event occurs in the next cases: 1. Standard situation: the vehicle passes through the checkpoint in the right direction when related event <i>Entry attempt</i> occurs and alarm sensors at the entrance triggered. Alarm sensors have to be triggered within the <i>Interval of number plate loss</i> . 2. Nonstandard situation: the vehicle passes through the checkpoint configured only for the exit. License plate recognized in the <i>Exit</i> recognition zone and algorithm of vehicle passage direction generates <i>Entry</i> status.
	Exit attempt	This event logged if the plate number recognized in the <i>Exit</i> zone and algorithm of vehicle passage direction generates status <i>Exit</i> or <i>Undefined</i> . Standard situation.
	Exit	The event occurs in the next cases: 1. Standard situation: the vehicle passes through the exit checkpoint when related event <i>Exit attempt</i> occurs and alarm sensors at the exit triggered. Alarm sensors have to be triggered within the <i>Interval of number plate loss</i> . 2. Nonstandard situation: the vehicle passes through the checkpoint configured only for the entry. License plate recognized in the <i>Entry</i> recognition zone and algorithm of vehicle passage direction generates <i>Exit</i> status.
	Entry attempt is not detected	This event can occur only if "Entry", "Exit" or "Exit attempt" detected, but "Entry attempt" not detected before. This can happen because of license plate recognition error in the entry area or sensors triggering error.
	Exit attempt is not detected	This event can occur only if "Exit" or "Re-entry" detected, but there was no "Exit attempt". This can happen due to license plate recognition error in the exit zone.
	Entry is not detected	This event can occur only if "Exit" or "Re-entry" it was detected. The reason may be in license plate recognition error, or sensors triggering error.
	Exit is not detected	This event can occur only if "Re-entry" detected. The reason may be in license plate recognition error, or sensors triggering error.

Table 9: One-directional checkpoints - passage states legend

Icon	State	Description
	Opened automatically	The command to open executive mechanisms (barrier or gate) sent automatically.
	Closed	The command to open executive mechanisms (barrier or gate) not sent.
	Opened by user's command	The command to open executive mechanisms (barriers or gates) sent via software control button by user.
	Opened by card	The command to open executive mechanisms (barriers or gates) is given after control module alarm input
	Passage successful	The event occurs only if entry or exit with confirmation configured. Vehicle with allowed access has successfully enter/leave the area.
	Violator	The event occurs only when entry with confirmation configured and denied vehicle enters the area or nonstandard situation occurs (the vehicle passes through the wrong checkpoint).

5.1.3 BI-DIRECTIONAL CHECKPOINTS WITH ENTRY CONFIRMATION

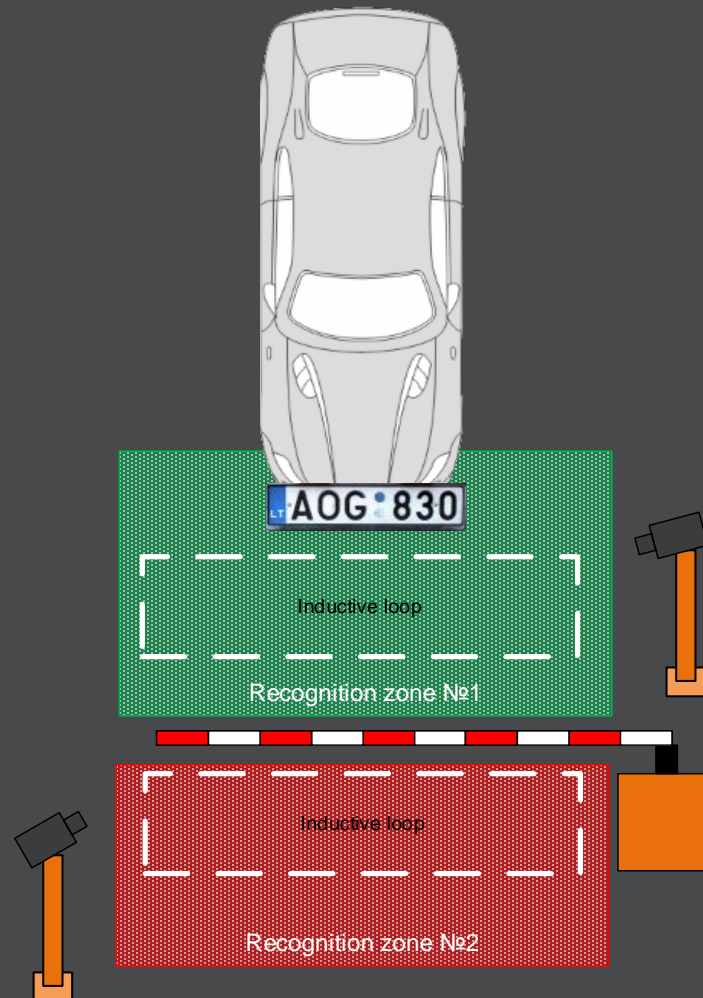

PICTURE 62: BI-DIRECTIONAL CHECKPOINT WITH ENTRY CONFIRMATION CHART

A checkpoint called “bi-directional” when the cars can enter and exit through it in two directions. To control this checkpoint you need two recognition areas, for entry and exit respectively.

To confirm the entry you can use alarm sensors (photocells or inductive loops) ([p.5.2.3.1](#)) or adjacent recognition zones ([p.5.2.3.2](#)).

The algorithm of determining the direction - to determine the movement all available algorithms can be used: by license plate movement in the frame ([p.5.2.2](#)), by adjacent recognition zones ([p.5.2.3.2](#)) and by the alarm sensors ([p.5.2.3.1](#)).

Table 10: Bi-directional checkpoint - passage events legend















Icon	Event	Description
	Entry attempt	The event occurs when the vehicle detected in the Entrance recognition zone and algorithm of vehicle passage direction generates status « <i>Entry</i> » or « <i>Undetermined</i> ».
	Entry	The event occurs when the vehicle detected in the Entrance recognition zone and algorithm of vehicle passage direction generates status « <i>Entry</i> » or <i>Undetermined</i> . OR alarm sensors at the entrance triggered in « <i>Entry</i> » sequence.
	Exit attempt	The event occurs when the vehicle detected in the Exit recognition zone and algorithm of vehicle passage direction generates status « <i>Exit</i> » or « <i>Undetermined</i> ».
	Exit	The event occurs when the vehicle detected in the Exit recognition zone and algorithm of vehicle passage direction generates status « <i>Exit</i> » or « <i>Undetermined</i> ». OR alarm sensors at the exit triggered in « <i>Exit</i> » sequence.
	Entry attempt is not detected	This event occurs only if "Entry", "Exit" or "Exit attempt" detected, but "Entry attempt" not detected. This can happen because of license plate recognition error in the entry area or sensors triggering error.
	Exit attempt is not detected	This event can occur only if "Exit" or "Re-entry" detected, but there was no "Exit attempt". This can happen due to license plate recognition error in the exit zone.
	Entry is not detected	This event can occur only if "Exit" or "Re-entry" detected without "Entry" event. The reason may be in license plate recognition error, or sensors triggering error.
	Exit is not detected	This event can occur only if "Re-entry" detected without "Exit" event. The reason may be in license plate recognition error, or sensors triggering error.

Table 11: Bi-directional checkpoint - passage states legend

Icon	State	Description
	Opened automatically	The command to open executive mechanisms (barrier or gate) sent automatically.
	Closed	The command to open executive mechanisms (barrier or gate) not sent.
	Opened by user's command	The command to open executive mechanisms (barriers or gates) sent via software control button by user.
	Opened by card	The command to open executive mechanisms (barriers or gates) given after receiving signal to the alarm input of control module
	Entry successful	The event occurs only if entry with confirmation configured. Vehicle with allowed access successfully enters the area.
	Violator	The event occurs only when entry with confirmation configured and denied vehicle enters the area or nonstandard situation occurs (the vehicle passes through the wrong checkpoint).

5.2 ALGORITHMS

5.2.1 LICENSE PLATE NUMBER RECOGNITION ALGORITHM

- Connection to the video stream;
- Video stream frame by frame decoding;
- License plate numbers detection



PICTURE 63: SEARCHING THE LICENSE PLATE IMAGE IN THE VIDEO FRAME

- Image normalization



- Image segmentation



- Symbols recognition
- Reprocessing of obtained data- layout of license plate numbers

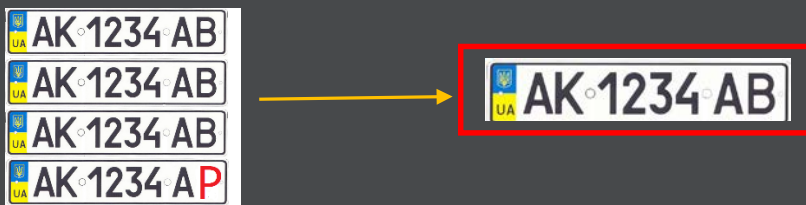

5.2.2 ALGORITHM FOR PLATE MOVEMENT DIRECTION IDENTIFICATION

To determine the vehicle travel direction the next requirements should fulfill:

- The vehicle course angle would be configured in a Settings - Connection - Recognition block setup (p.4.9.2.2);
- License plate number would be recognized at least twice and with different coordinates;
- The vehicle movement vector would not differ from course angle more than $\pm 15^\circ$.

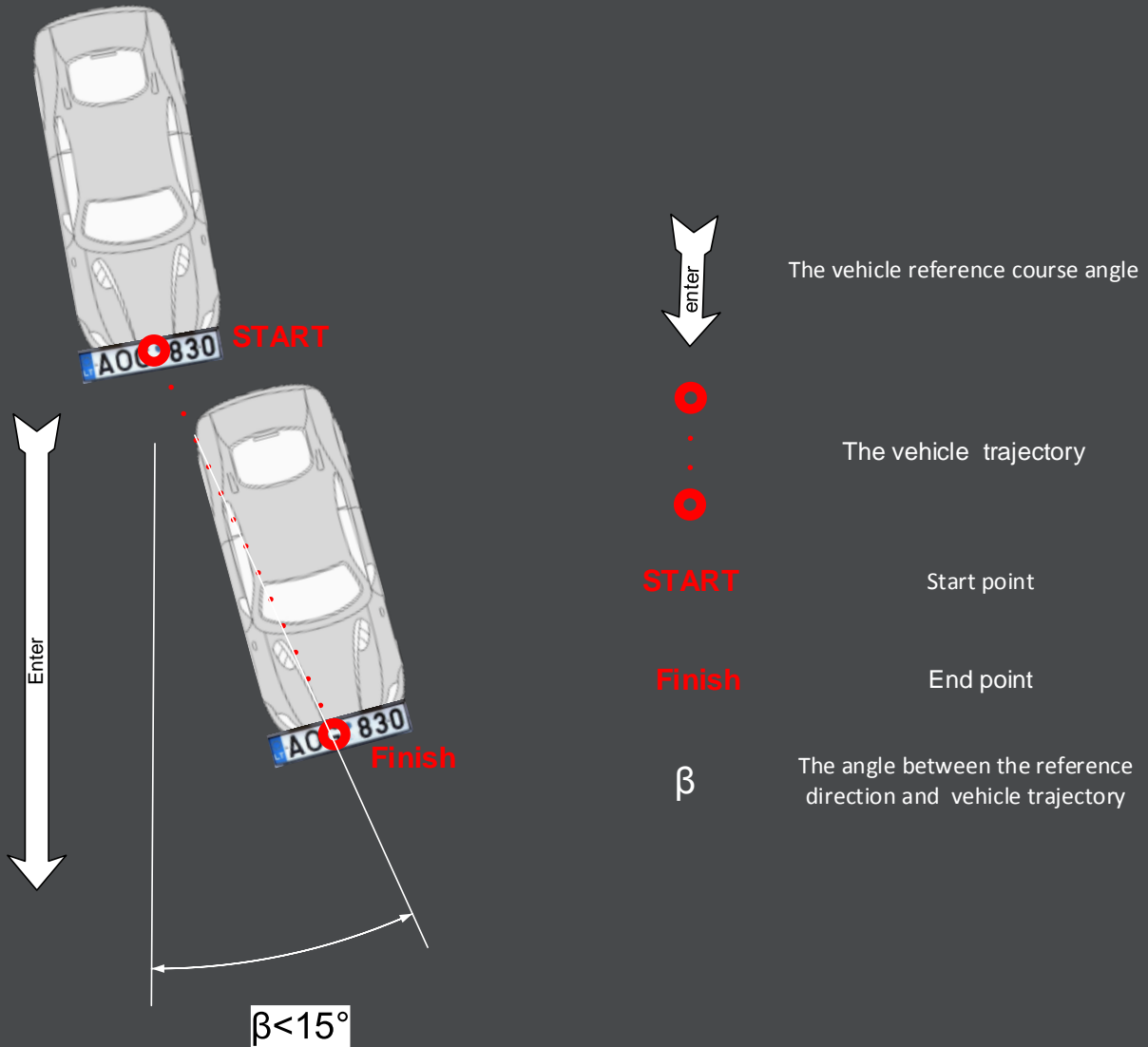

PICTURE 64: VEHICLE TRAVEL DIRECTION IDENTIFICATION BY LICENSE PLATE NUMBER MOVEMENT CHART

5.2.3 ALGORITHM FOR ENTRY DETECTION

5.2.3.1 PASSAGE DETECTION BY ALARM SENSORS (PHOTOCELLS OR INDUCTIVE LOOPS)

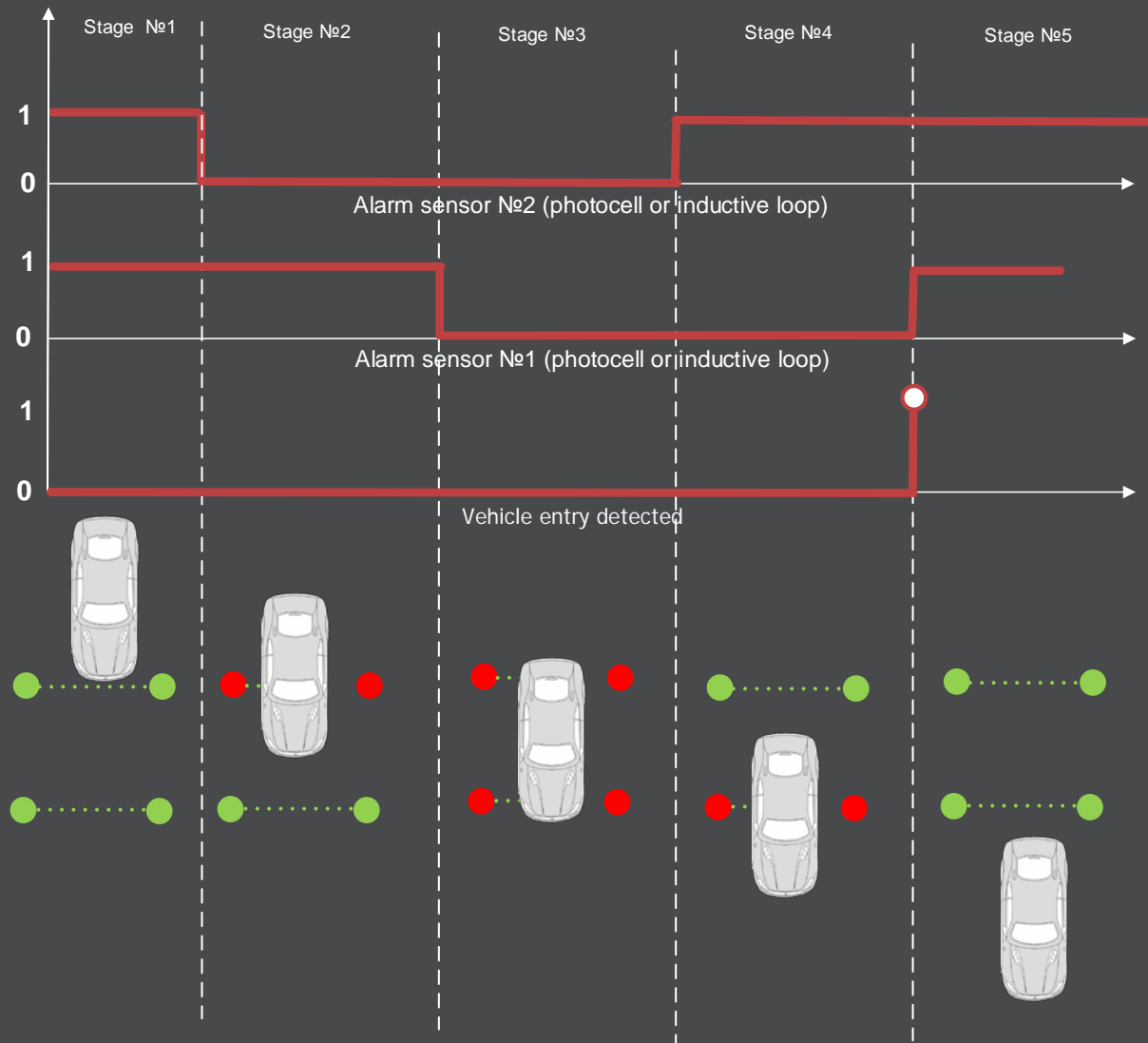

PICTURE 65: OPERATION DIAGRAM OF PASSAGE DETECTION ALGORITHM BY ALARM SENSORS

1. Stage 1 - both sensors are normally closed (or open) - there are no any cars;
2. Stage 2 - the first sensor is open (or closed) - the car is in the first sensor area;
3. Stage 3 - both sensors are open (or closed) - the car is in the both sensors areas;
4. Stage 4 - the first sensor is closed (or open) - the car has passed the first sensor and currently passing the second sensor;
5. Stage 5 - the second sensor is closed (or open) - the car has passed both sensors.

When all the five stages completed, the system generates event of vehicle entry detection by alarm sensors. When the first triggered sensor is located at the entrance, the **Entry** event will generated; if the exit sensor triggered first, the **Exit** event will generated. See the connection diagram of executive units ([p.3.3.2](#), [p.3.3.3](#)) and checkpoint connection setup ([p.4.9.3.1](#)).

5.2.3.2 PASSAGE DETECTION BY ADJACENT RECOGNITION ZONES

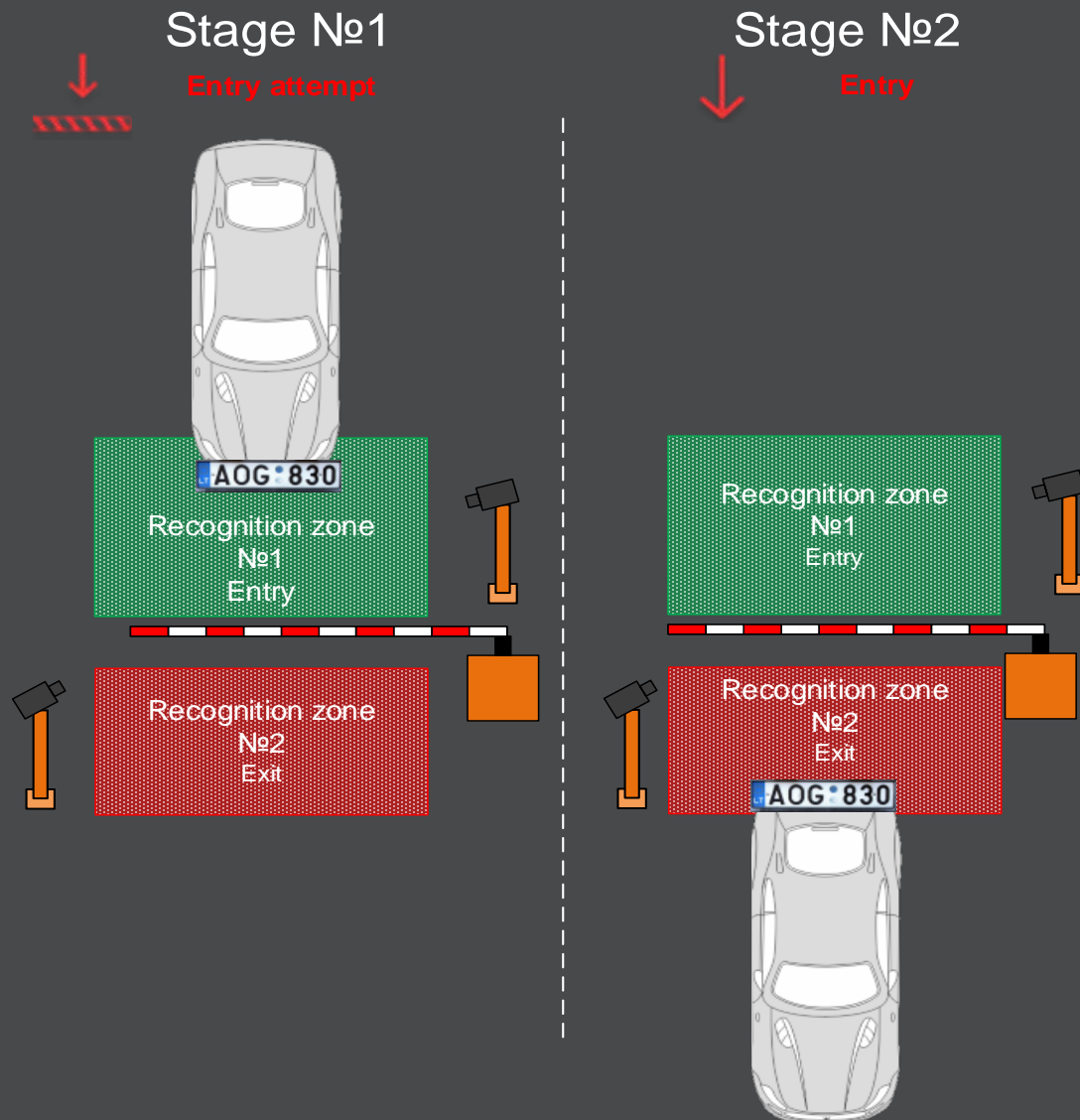

PICTURE 66: OPERATION DIAGRAM OF PASSAGE DETECTION ALGORITHM BY ADJACENT RECOGNITION ZONES

1. Stage 1 - detection of license plate in the Entry recognition zone (detection of Entry attempt event);
2. Stage 2 - detection of the same license plate number within the Interval of number plate loss in the Exit recognition zone (*Entry* event);
3. When the listed stages sequence occurs in the opposite order of travel direction, the Exit attempt and Exit events will generates.

5.2.4 ALGORITHM FOR CALCULATION OF VEHICLE STAY AT THE TERRITORY DURATION

Duration of the vehicle "stay at the area" time calculated using the formula shown below:









$$T_d = T_{\text{departure}} - T_{\text{entry}}, \text{ where}$$

$T_{\text{departure}}$ - time of detection the vehicle Exit;

T_{entry} - time of detection the vehicle Entry.

5.3 LEGEND

Table 12: The vehicle passage direction events legend

Icon	Event	Description
	Entry attempt	The event occurs in «Checkpoint» and «Parking» modes, when entry with confirmation configured (p.5.2.3). It means that the vehicle is standing in front of checkpoint and attempts to enter, but confirmation of this event not yet received.
	Entry	The event may occur in any operation mode (p.5.2.2)
	Exit attempt	The event occurs only in «Checkpoint» and «Parking» modes, when «Exit with confirmation» configured (p.5.2.3). It means that the vehicle is standing before the checkpoint and attempts to leave, but confirmation of «Exit» not yet received.
	Exit	The event may occur in any operation mode (p.5.2.2)
	Direction undetermined	Algorithm could not determine vehicle passage direction. It can happened only when single recognition occurs. Therefore it is impossible to determine shift direction of number plate.
	Entry attempt not detected	The event occurs only when «Entry», «Exit» or «Exit attempt» detected, but «Entry attempt» not detected. It can happen only when the license plate recognition error occurs in the Entrance area.
	Exit attempt not detected	The event occurs only when «Entry» or «Re-Entry» event detected, but «Exit attempt» not detected. It can happen only when license plate recognition error occurs in the Exit area.
	Entry not detected	The event occurs only when «Exit» or «Re-Entry» detected, but «Entry» not detected. It can happen when license plate recognition error occurs, or false sensor alarm triggered.
	Exit not detected	The event occurs when «Re-Entry» detected, but «Exit» not detected. It can happen when license plate number recognition error occurs or false sensor alarm triggered.

The next settings influence the parameters above:

- Vehicle course angle in Settings-Connection-Recognition block setup (p.4.9.2.2);
- Recognition zone settings in the Checkpoint tab (p.4.9.3.1)
- Alarm sensor settings in the Checkpoint tab (p.4.9.3.3)

Table 13: Passage states legend











Icon	State	Description
	Opened automatically	The command to open executive mechanisms (barrier or gate) sent automatically.
	Closed	The command to open executive mechanisms (barrier or gate) not sent.
	Opened by user's command	The command to open executive mechanisms (barriers or gates) sent via software control button by user.
	Opened by card	The command to open executive mechanisms (barriers or gates) is given after control module alarm input
	Passage successful	The event occurs only when entry or exit with confirmation configured. Vehicle with allowed access has successfully enter/leave the area.
	Violator	The event occurs only when entry with confirmation configured and denied vehicle enters the area or nonstandard situation occurs (the vehicle passes through the wrong checkpoint).

Table 14: Access states legend

Icon	State	Description
	Allowed	The entry always allowed for all vehicles
	Denied	The entry always denied for all vehicles
	Allowed on schedule	The entry allowed for vehicles in the described time and date range
	Allowed by entries number	The entry allowed for vehicles when the entries amount not exceeded
	Allowed by duration	The entry allowed for vehicles when the duration time not exceeded

6 TROUBLESHOOTING

1. When NumberOk interface prevents any parameter changes but the "mouse" is functioning properly, you need to check whether authentication was made and whether the current user allowed to make adjustments in this paragraph;
2. Difficulties with entering and accepting the NumberOk license key can be caused by lack of Internet connection during the software installation process, it should be uninterrupted during installation process;
3. Changing the username and password to access the database when installing Firebird for NumberOk server configuration **prohibited!** Setting of a new authorization pair have to provide by external Firebird database management tools;
4. Errors when trying to start and stop the operation of NumberOk as a Windows Service in most cases occurs due to the fact that utilities have to be launched as administrator, but not the current user ([p.4.4](#));
5. The absence of any recognize trying of license plates or rare incorrect recognitions, taken places under stipulated viewing angles and license plates sizes ([p.3.1.3](#) and [p.3.2](#)) can be caused by incorrect setting of minimum and maximum amount of characters in the recognized plates. An additional feature of this error - a wrong recognition of the country, where plates registered. Valid values, corresponding to the observed numbers, have to be configure in the sub-tab "General" of basic settings tab ([p.4.9.1](#));
6. A common mistake of mask pattern settings for license plates recognition: using a quantifier "*" instead of "+". The second specifies any number of characters, starting with one, but the first permits no character presence too;
7. When the reactions editor's tools are not active - check settings of a tick "reaction active" in the upper left corner of the reactions editor's window. It would be set ON to adjust the events and reactions parameters;
8. When only the first reaction works from the several reactions list on the same type events, except all the rest, you have to check the status of the reactions **executing** radio buttons in the lower right corner of the reactions sub-tab ([p.4.8.3.2](#)). To execute several reactions on the same type events turn ON a "Process all to the end of list" radio button.

7 APPENDIX

7.1 TYPICAL RTSP STRINGS FOR SOME MANUFACTURERS EQUIPMENT

Table 15 Typical RTSP strings for some manufacture's equipment

Manufacturer	Connection string
AXIS	rtsp:// LOGIN:PASSWORD@ <camera IP address>/mpeg4/media.amp
Bosch	rtsp:// LOGIN:PASSWORD@<camera IP address>/rtsp_tunnel
D-Link	rtsp:// LOGIN:PASSWORD@<camera IP address>/play1.sdp
Hikvision	rtsp:// LOGIN:PASSWORD@ <camera IP address>:554/h264
Micro Digital	rtsp:// LOGIN:PASSWORD@<camera IP address>/cam0_0
Panasonic	rtsp:// LOGIN:PASSWORD@ <camera IP address>/MediaInput/mpeg4
Samsung	rtsp:// LOGIN:PASSWORD@<camera IP address>/h264/media.smp
Sony	rtsp:// LOGIN:PASSWORD@<camera IP address>/media/video1
TP-Link	rtsp:// LOGIN:PASSWORD@<camera IP address>/video.mp4
Vivotek	rtsp:// LOGIN:PASSWORD@<camera IP address>/live.sdp
Novus	rtsp:// LOGIN:PASSWORD@<camera IP address>:554/h264
Partizan	rtsp:// LOGIN:PASSWORD@<camera IP address>: PORT /user= LOGIN & PASSWORD =&channel=1&stream=0.sdp
TVT	rtsp:// LOGIN:PASSWORD@<camera IP address>:554/h264
Avigilion	rtsp:// LOGIN:PASSWORD@<camera IP address>
Cisco	rtsp:// LOGIN:PASSWORD@<camera IP address>/img/media.sav
D-Link	rtsp:// LOGIN:PASSWORD@ip_adx/play1.sdp
GeoVision	rtsp:// LOGIN:PASSWORD@ip_adx:8554/CH001.sdp
Honeywell	rtsp:// LOGIN:PASSWORD@ip_adx/h264
LG	rtsp:// LOGIN:PASSWORD@<camera IP address>/
Toshiba	rtsp:// LOGIN:PASSWORD@<camera IP address>/live.sdp

Examples for other manufacturers you can find at website www.number-ok.com in the tab: NumberOK -> Product -> RTSP Sources.

7.2 EXAMPLE OF VEHICLES DATABASE EXPORT TO *.XLS FORMAT

	A	B	C	D	E	F	G	H	I	J	K	L	M	N
1		Id	Country	umber pla	Owner	Group								
2	25	Belarus	AA27951	AA27951	Owners2									
3	114	Belarus	8003AA	8003AA	Guests									
4	164	Belarus	0974AQ	0974AQ	Guests									
5	313	Belarus	814B	814B	Guests									
6	314	Belarus	NF84B	NF84B	Guests									
7	33	Latvia	AA7278	AA7278	Guests									
8	41	Lithuania	HGD675	HGD675	Owners2									
9	285	Lithuania	51656KP	51656KP	Guests									
10	315	Netherland	40SPJ2	40SPJ2	New group "Denied"									
11	316	Netherland	76ZTT3	76ZTT3	New group "Denied"									
12	317	Netherland	70JGKZ	70JGKZ	New group "Denied"									
13	318	Netherland	90LDT	90LDT	New group "Denied"									
14	319	Netherland	37BPGK	37BPGK	New group "Denied"									
15	320	Netherland	24XGXT	24XGXT	New group "Denied"									
16	321	Netherland	65ZGZB	65ZGZB	New group "Denied"									
17	322	Netherland	17ZRN1	17ZRN1	New group "Denied"									
18	323	Netherland	31SPV1	31SPV1	New group "Denied"									
19	324	Netherland	41STS1	41STS1	New group "Denied"									
20	325	Netherland	1XDS52	1XDS52	New group "Denied"									
21	326	Netherland	67RPN6	67RPN6	New group "Denied"									
22	327	Netherland	40XRK8	40XRK8	New group "Denied"									
23	328	Netherland	96PHH5	96PHH5	New group "Denied"									
24	329	Netherland	234064O	234064O	New group "Denied"									
25	330	Netherland	60PSXK	60PSXK	Owners1									

PICTURE 67: CARS DATABASE EXPORT TO *.XLS FORMAT SCREENSHOT

7.3 THE LICENSE PLATES PATTERNS

To describe the set of recognized license plates with a similar structure you can use masks from regular expressions. Basic elements of license plates masks shown in the table:

Table 16: Frequently used special symbols and expressions for license plates templates

Element	Description
Character (e.g. «c»)	A character represents itself unless it has a special regular expression meaning. E.g., c matches the character "c".
A character that follows a backslash (e.g. «\c»)	A character that follows a backslash matches the character itself, except as specified below.
.	(dot) Matches any character
*	(e.g. «x*») Matches <u>zero</u> or more occurrences of character before "*"
+	(e.g. «x+») Matches <u>one</u> or more occurrences of character before "+"
?	(e.g. «x?») Matches zero or one occurrences of character before "?"
\d	Matches a digit
\D	Matches a non-digit
\s	Matches a whitespace character
\S	Matches a non-whitespace character
X{y,z}	B Matches at least n and at most m occurrences of "X".
(e.g. «x{y,z}»)	
[]	(e.g. [A-D]) An expression can also be a set of characters enclosed in square brackets. [ABCD] will match an A or a B or a C or a D. We can write this same expression as [A-D], and an expression to match any capital letter in the English alphabet is written as [A-Z]
()	Parentheses group expressions together, and they identify a part of the regular expression that we wish to capture.
	We can use the vertical bar , which means "OR"
^, \$	Matches the begin and the end of the string
\a, \b, \f, \n, \r, \t, \v, \x, \0	Additional regular expressions masks. You can find it meanings at www.wikipedia.org/wiki/Regular_expression

Quantifier and characters set can be combined in a single expression, for example: [0-9]{1,2} - any sequence of integers with one to two characters.