



SDO-502(V2)

Amortizor electric cu brat pentru usi batante cu latime de pana la 1200mm si greutate de pana la 100kg, cu deschidere la exterior

Imagine



Descriere

Amortizor electric cu brat pentru usi batante cu latime de pana la 1200mm si greutate de pana la 100kg, cu deschidere la exterior.

Suporta sincronizare si interblocare intre doua usi, alimentare accesorii.

Aplicatia mobila "SOCA BLE Management" permite configurarea facila si accesul la loguri.

Aplicatie mobila

Aplicatie mobila "SOCA BLE Management" disponibila gratuit in Google Play sau App Store pentru o instalare si configurare cat mai facila.

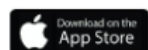

Caracteristici

- Comunicatie Bluetooth 2.4G
- Aplicatie mobila "SOCA BLE Management"
- Instalarea si configurare usoara din APP
- Deschidere din aplicatia mobila
- Deschidere usa: stanga/dreapta, spre exterior
- Sincronizare si interblocare
- 3 moduri de functionare: AUTO, ONE-WAY, OPEN
- Motor fara perii
- Timp mentinere usa deschisa ajustabil 1-255 sec.
- Semnalizare Led stare si buzzer
- Limitator capat de cursa pe brat pentru a limita deschiderea maxima a usii (max. 120°)
- Auto-invitare pozitie brat dupa alimentare
- Franare la capat de cursa (ajustabil)
- Viteza deschidere/inchidere ajustabila
- Forta anti-coliziune ajustabila
- Reversal Time, pentru a debloca usa chiar daca aceasta se afla sub presiune
- Forta la inchidere ajustabila (Wind Resistance)

Specificatii

• Alimentare:	90~264Vca, 50/60Hz
• Consum:	72W, 24Vcc@3A
• Forta maxima:	45Nm
• Viteza motor:	1800 rpm
• Latime canat usa:	min. 81cm ~ max. 120cm
• Greutate usa:	100kg
• Unghi deschidere:	max. 120°
• Alimentare accesorii:	24Vcc@0.5A
• Releu incuietoare:	NO-COM-NC, 24Vcc@2A
• Expunere la zgomot:	≤55dB
• Temporizare:	1-255 sec.
• Stocare loguri in App:	5000
• Culori disponibile:	Gri, negru
• Dimensiune toc:	Min. 10cm, max.30cm
• Temperatura de functionare:	-20°C ~ +60°C
• Dimensiuni:	532(L) x 74(l) x 70(A)mm
• Masa bruta:	5kg

Latime canat usa si greutate

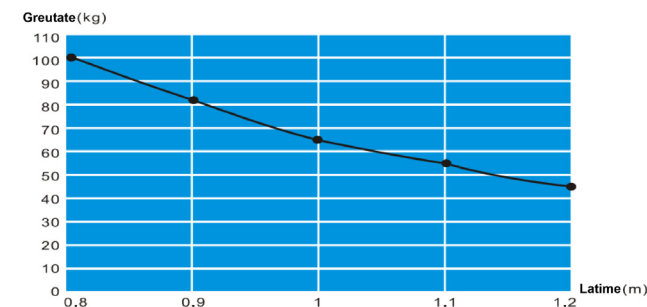

Parti componente

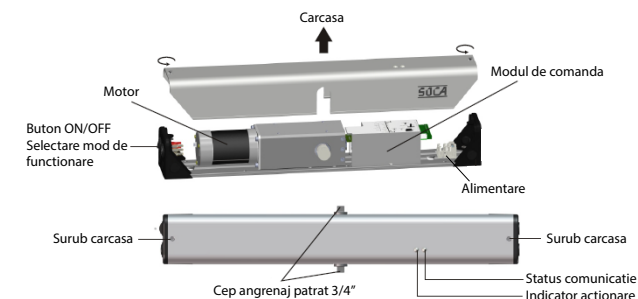

Continut pachet

- 1 x SDO-502(V2)
- 1 x Brat
- 1 x Pachet accesorii de prindere



Conexiuni electrice

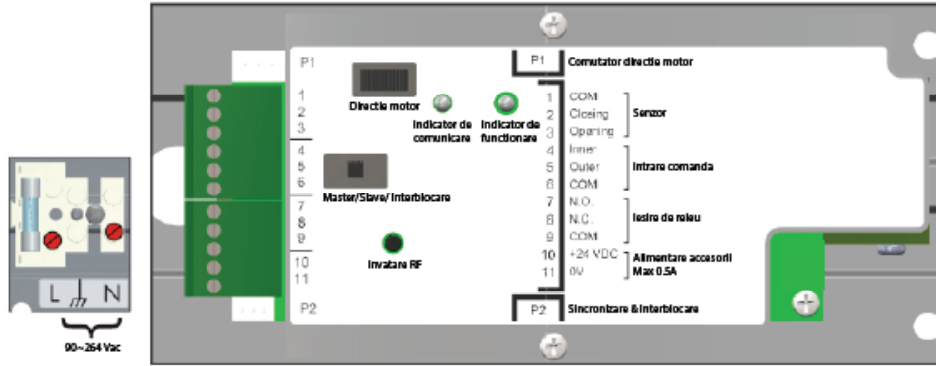

YLI ETERNIT ACCES srl
 A.: HAIDUCULUI 3A, CLUJ-NAPOCA
 T.: +40 264 484989
 W.: www.yli.ro

Aplicatii

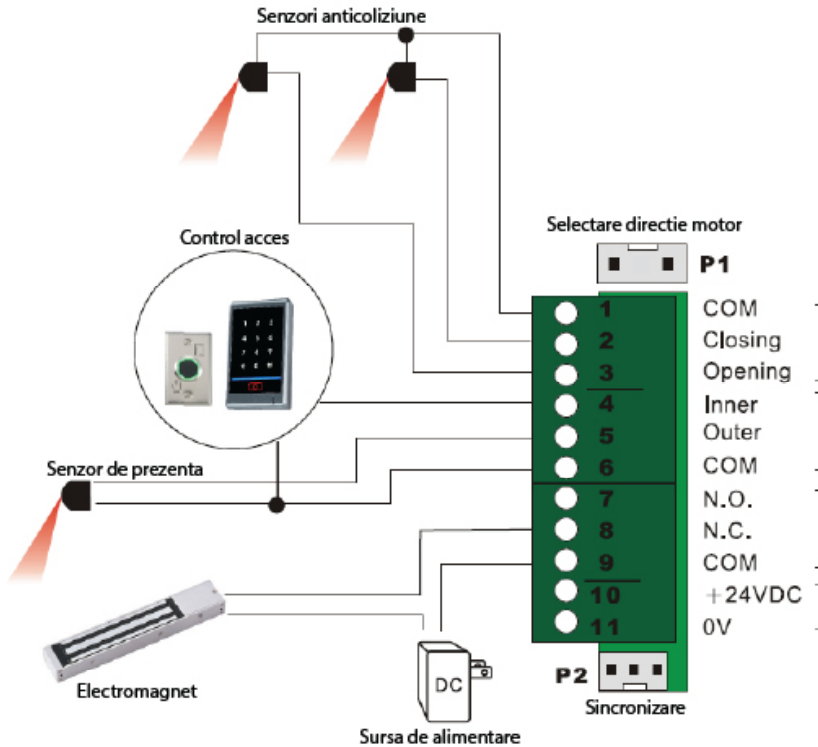

SDO-502(V2)
 Amortizor electric cu brat pentru usi batante cu latime de pana la 1200mm si greutate de pana la 100kg, cu deschidere la exterior
FISA TEHNICA

Dimensiuni

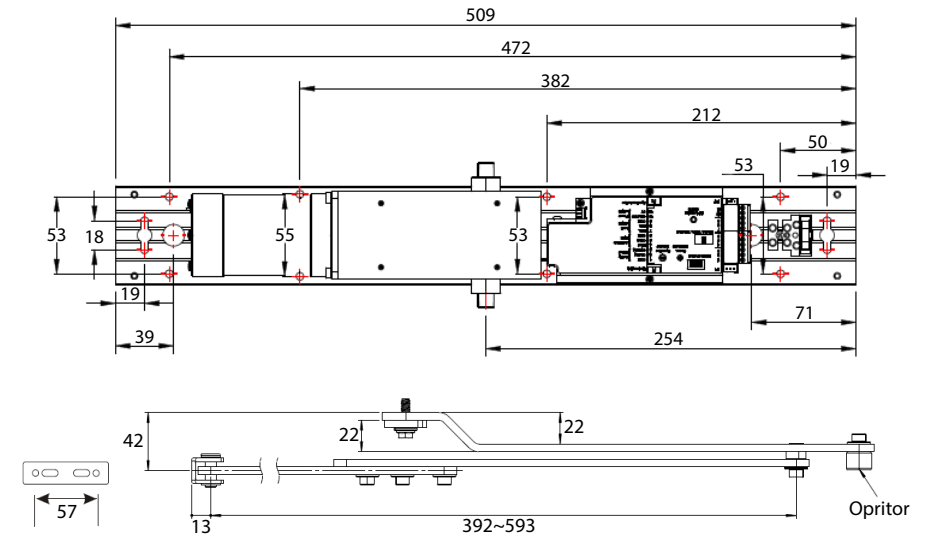
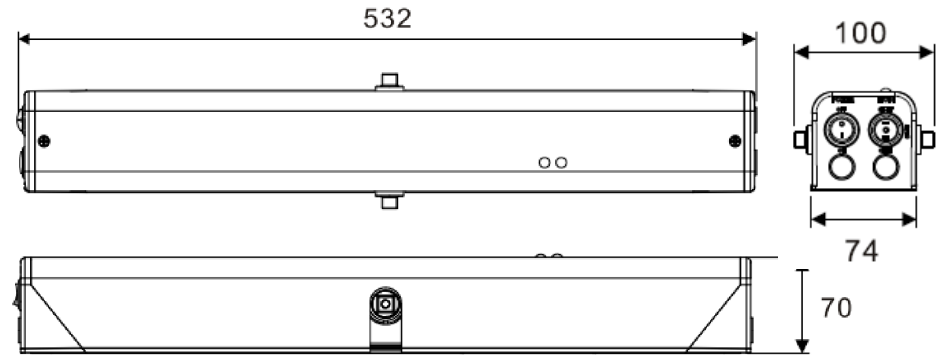

Observatii



EEE FAC OBIECTUL UNEI
 COLECTARI SEPARATE

