



BMTV-537

Turnichet vertical semi-automat cu o cale de acces

Imagine



YLI ETERNIT ACCES srl
A.: HAIDUCULUI 3A, CLUJ-NAPOCA
T.: +40 264 484989
W.: www.yli.ro

BMTV-537
Turnichet vertical semi-automat
cu o cale de acces
FISA TEHNICIA

Descriere



Turnichet vertical semi-automat cu o cale de acces conceput pentru a oferi acces nesupervizat in locatiile cu securitate ridicata.

Constructia impenetrabila elimina orice acces neautorizat in zonele restrictionate. Constructia rigida din otel inoxidabil, ofera siguranta deplina si rezistenta crescuta la vandalism, garantand o operare lipsita de probleme pentru multi ani chiar si in medii nefavorabile. Actionarea electromagnetica, mecanismul si amortizorul hidraulic asigura o operare lina si silentioasa.

Caracteristici

- Operare bi-directionala
- Control electronic pentru ambele directii
- Integrare facila cu sistemele de control acces
- Reblocare automata dupa fiecare actionare (5 secunde)
- Conectare buton pentru situatii de urgenta
- Operare la interior sau exterior
- Mecanism de precizie robust, placat cu nichel pentru rezistenta mare la coroziune
- Mecanism anti-blocare la trecere
- Asamblare modulara pentru instalarea in spatii inguste
- Acces facil la componentele electronice
- Sistem electronic modular pentru depanare rapida
- Parametri programabili electronic
- In caz de intrerupere a alimentarii ramane deschis
- Releu counter NO-COM-NC pentru intrare si iesire
- Mecanism cu auto-centrare ce asigura o rotatie completa
- Mecanism anti-revenire dupa ce rotorul s-a invartit 30° de la pozitia de repaus
- Amortizor hidraulic ce asigura o operatie lina si silentioasa
- Carcasa din otel inoxidabil cu un grad de rezistenta ridicat la coroziune
- Protectie la intemperii IP45

Specificatii

• Alimentare:	230Vca, 50/60 Hz
• Temperatura:	-20°C ~ +70°C
• Umiditate:	<90%
• Protectie la intemperii:	IP45
• Alimentare controler:	24Vcc
• Consum total:	50W
• Comanda:	Contact uscat (NO)
• Timp deschidere:	<1sec
• Capacitate treceri:	35-50 pers/ min/ cale
• Material:	Otel Inoxidabil 304
• Dimensiuni exteriorare:	1400(l) x 1300(A) x 2230(H) mm
• Dimensiuni cale trecere:	600(l) mm
• Greutate neta:	125 Kg
• Greutate bruta:	145 Kg

Dimensiuni

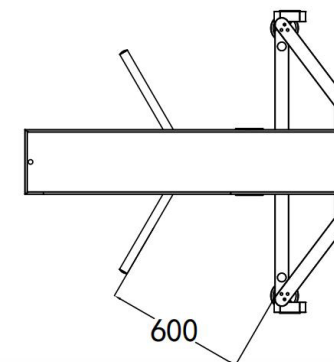
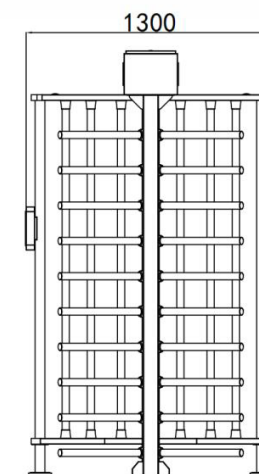
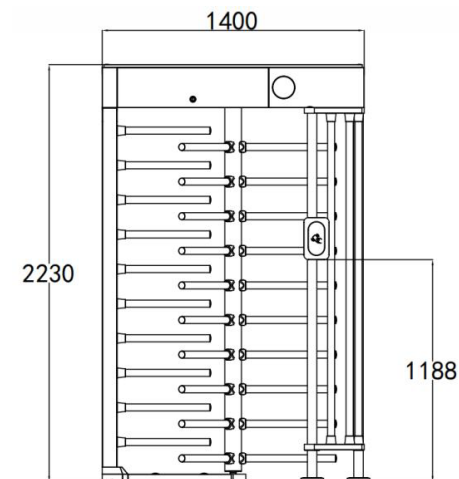



YLI ETERNIT ACCES srl
A.: HAIDUCULUI 3A, CLUJ-NAPOCA
T.: +40 264 484989
W.: www.yli.ro

BMTV-537
Turnichet vertical semi-automat
cu o cale de acces
FISA TEHNICIA

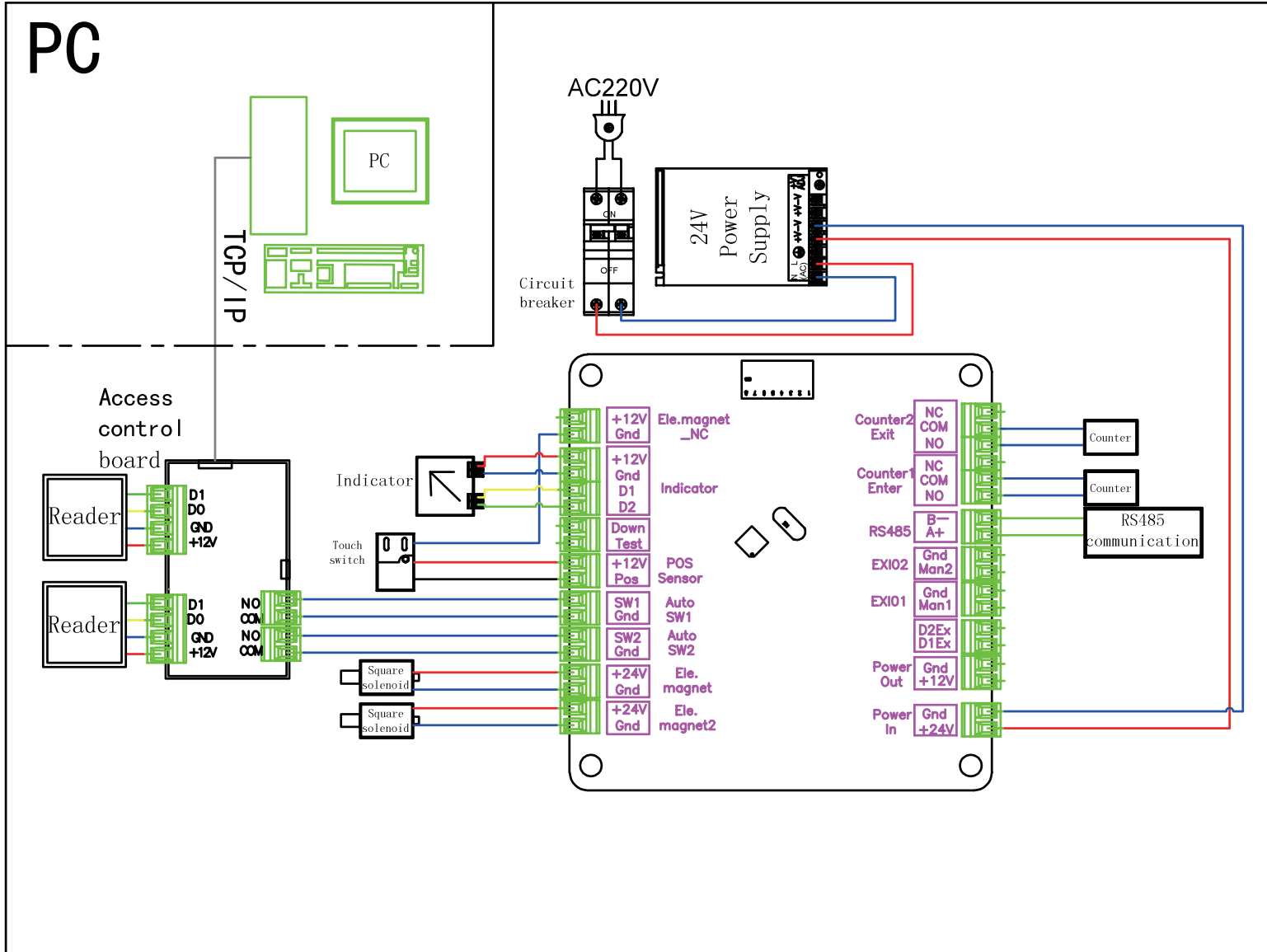

Observatii



EEE FAC OBIECTUL UNEI
COLECTARI SEPARATE

