



YLI ETERNIT ACCES srl  
A.: HAIDUCULUI 3A, CLUJ-NAPOCA  
T.: +40 264 484989  
W.: www.yli.ro

# SDO-501(V2)

Amortizor electric cu sina pentru usi batante cu latime de pana la 1200mm si greutate de pana la 100kg, cu deschidere la exterior/interior

## Imagine



## Descriere

Amortizor electric cu sina pentru usi batante cu latime de pana la 1200mm si greutate de pana la 100kg, cu deschidere la exterior/interior.

Suporta sincronizare si interblocare intre doua usi, alimentare accesorii.

Aplicatia mobila "SOCA BLE Management" permite configurarea facila si accesul la loguri.

## Aplicatie mobila

Aplicatie mobila "SOCA BLE Management" disponibila gratuit in Google Play sau App Store pentru o instalare si configurare cat mai facila.



SDO-501(V2)

Amortizor electric cu sina pentru usi batante cu latime de pana la 1200mm si greutate de pana la 100kg, cu deschidere la exterior/interior

FISA TEHNICA

## Caracteristici

- Comunicatie Bluetooth 2.4G
- Aplicatie mobila "SOCA BLE Management"
- Instalarea si configurare usoara din APP
- Deschidere din aplicatia mobila
- Deschidere usa: stanga/dreapta, spre exterior/interior
- Sincronizare si interblocare
- 3 moduri de functionare: AUTO, ONE-WAY, OPEN
- Motor fara perii
- Timp mentinere usa deschisa ajustabil 1-255 sec.
- Semnalizare Led stare si buzzer
- Limitator capat de cursa pe sina pentru a limita deschiderea maxima a usii (max. 120°)
- Auto-invatare pozitie dupa alimentare
- Franare la capat de cursa (ajustabil)
- Viteza deschidere/inchidere ajustabila
- Forta anti-coliziune ajustabila
- Reversal Time, pentru a debloca usa chiar daca aceasta se afla sub presiune
- Forta la inchidere ajustabila (Wind Resistance)

## Specificatii

- |                               |                               |
|-------------------------------|-------------------------------|
| • Alimentare:                 | 90~264Vca, 50/60Hz            |
| • Consum:                     | 72W, 24Vcc@3A                 |
| • Forta maxima:               | 45Nm                          |
| • Viteza motor:               | 1800 rpm                      |
| • Latime canat usa:           | min. 81cm ~ max. 120cm        |
| • Greutate usa:               | 100kg                         |
| • Unghi deschidere:           | max. 120°                     |
| • Alimentare accesorii:       | 24Vcc@0.5A                    |
| • Releu incuietoare:          | NO-COM-NC, 24Vcc@2A           |
| • Expunere la zgomot:         | ≤55dB                         |
| • Temporizare:                | 1-255 sec.                    |
| • Stocare loguri in App:      | 5000                          |
| • Culori disponibile:         | Gri, negru                    |
| • Dimensiune toc:             | 0~11.5cm, deschidere exterior |
| • Temperatura de functionare: | -20°C ~ +60°C                 |
| • Dimensiuni:                 | 532(L) x 74(l) x 70(A)mm      |
| • Masa bruta:                 | 5kg                           |

## Latime canat usa si greutate

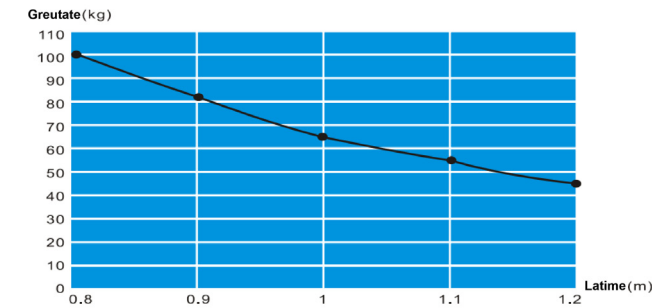

## Parti componente

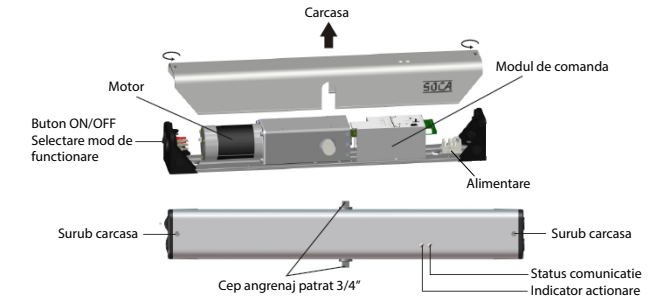

## Continut pachet

- 1 x SDO-501(V2)
- 1 x Sina
- 1 x Pachet accesorii de prindere



# Conexiuni electrice

YLI ETERNIT ACCES srl  
A.: HAIDUCULUI 3A, CLUJ-NAPOCA  
T.: +40 264 484989  
W.: www.yli.ro

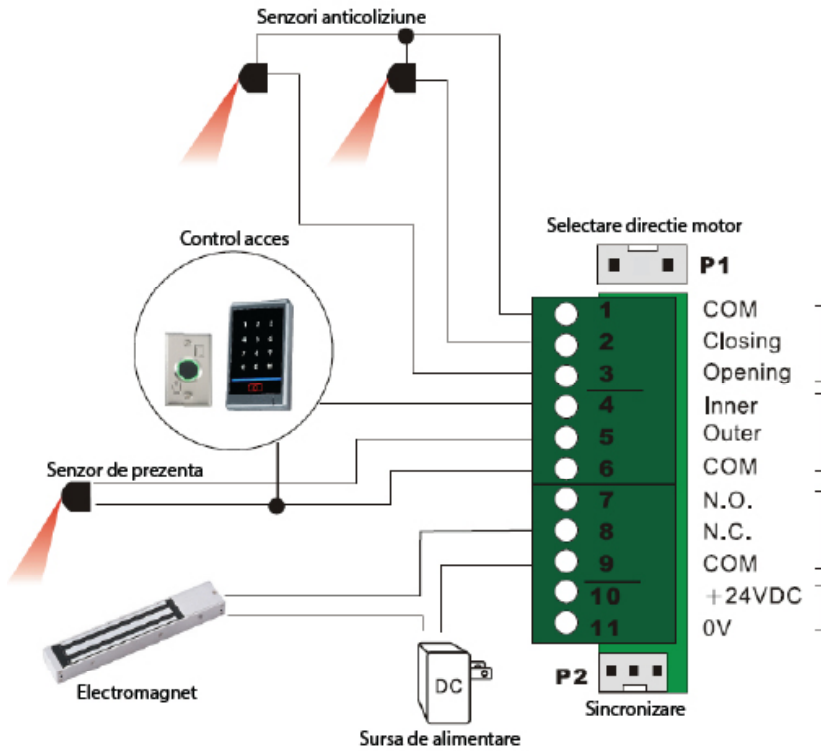
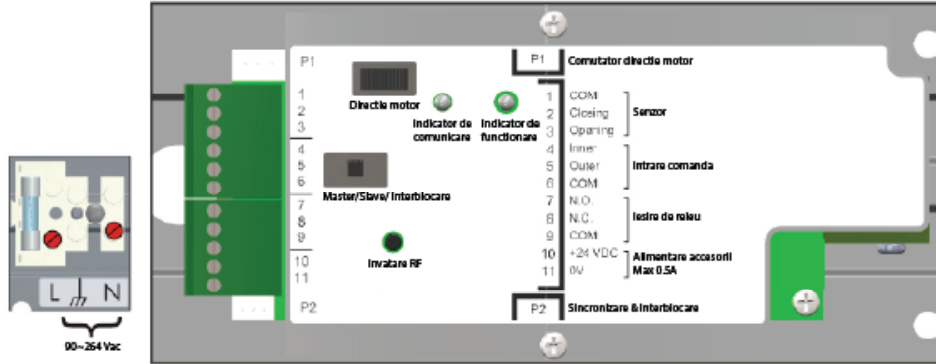

SDO-501(V2)

Amortizor electric cu sina pentru usi batante cu latime de pana la 1200mm si greutate de pana la 100kg, cu deschidere la exterior/interior  
FISA TEHNICA

# Dimensiuni

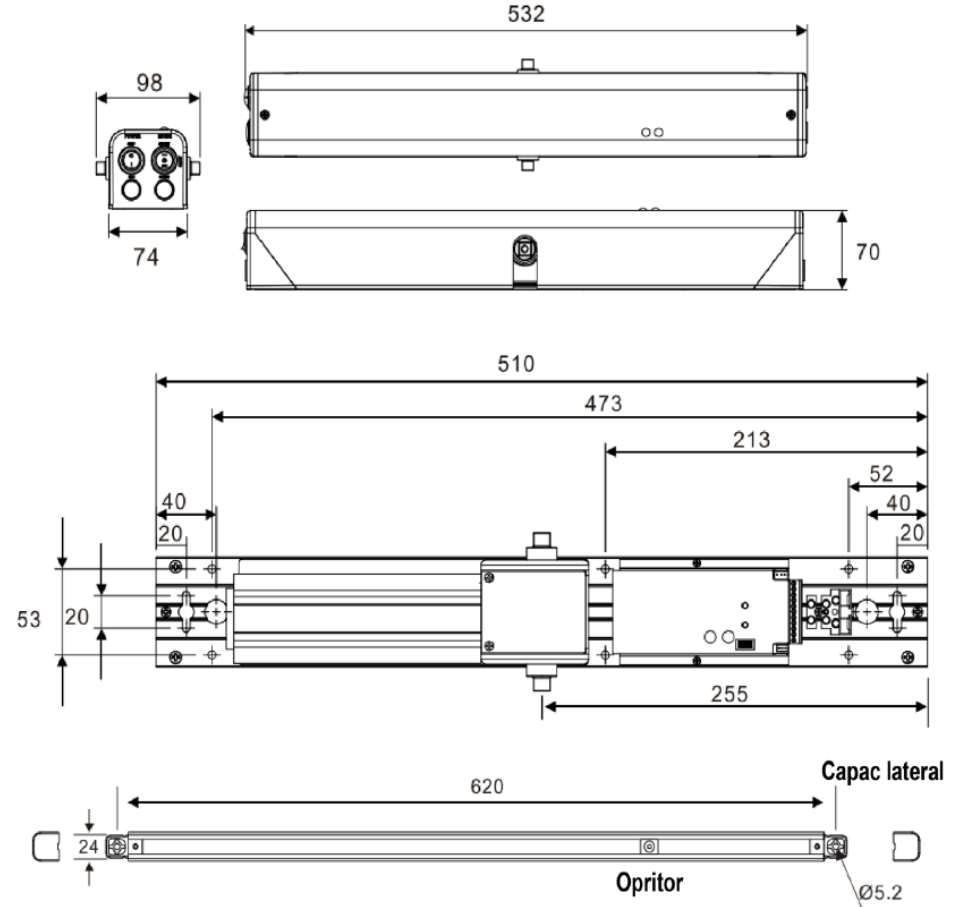

## Observatii



EEE FAC OBIECTUL UNEI  
COLECTARI SEPARATE

